



4G

Cam switches

GENERAL INFORMATION

4G-series cam switches are low voltage switches, designed according to the latest knowledge about switchgear and using the achievements of modern engineering. Only high quality insulation and contact materials have been used in these products. Basic components and units are standardized and massproduced, making it possible to make switches performing any switching programs, and short delivery terms.

Switches can be produced in many versions and have various applications. They conform all requirements for low voltage switches in industry, mining, shipbuilding, etc. They can be used as handoperated switches in transformer stations, control switchboxes and boards, switchgears made of cast iron or other metals, welding machines and similar devices.

4G-series switches are characterized by small external dimensions, powerful switching capabilities, long contact life and high mechanical stability, and resistance to short-lasting overloads. When additionally protected with fuses, they are also resistant to dynamic effects of short-circuit currents.

APPLICATION

Cam switches can be used in main and auxiliary circuits, especially:

- as switches for electric motors for switching and controlling the drives with single- and three-phase motors, as stardelta switches, reversing switches and switches for changing the rotational speed, etc.,
- in auxiliary, controlling, signalling and measuring circuits, manufactured according to the required switching program,
- as breaker switches, change-over switches and tap switches, for example for transformers and electric welding machines,
- as switchgroups, for example to connect resistors and heating elements,
- as change-over switches working as push-buttons with automatic returning to an off position,
- as switch disconnectors.

CONFORMITY WITH STANDARDS

4G-series cam switches fully comply with the requirements of the following standards: 93/E-06150/10, 93/E-06150/30, IEC 947-1, IEC 947-3.

These switches have Recognition Certificate of the Polish Register of Shipping, and CE Declaration of conformity of the European directive 73/23/EEC.

DIVISION

Basic division of switches and their marking is based on the rated current. Further division, based on external dimensions of the switches, enables to distinguish three groups characterized by overall dimensions. Each group has the same knobs, front plates and spacing for mounting holes.

Table 126. Division into groups

Group	A0	A1		A2		A3	
Switch type	4G10	4G16	4G25	4G40	4G63	4G80	4G100
Rated current I_n [A]	10	16	25	40	63	80	100

DESIGN

Depending on the switching program, every cam switch consists of a certain number of switching elements, which can be easily assembled together. Switching elements' bodies are made of plastics based on melamine, especially resistant to the effects related to creep currents and electric arcs.

A switching element has one or two current circuits arranged at the angle of 180° and equipped with contact with a double contact gap. Each of them consists of two stationary contacts and one movable contact bridge. The contact bridge is switched on (pressed) by contact springs, and opened by a cam inside the switching element. The cams in individual switching elements are firmly coupled together, ensuring practically simultaneous switching (on and off) of all contacts. Thanks to the double gap contact assembly and contact tips made of special alloy containing silver and very resistant to effects of an electric arc, high switching capabilities and contact life have been obtained. Good clicking mechanism of a motion work ensures unfailing switching of moving contacts in respective fixed positions. The power springs of the clicking mechanism are different, depending on the number of the switching elements. According to individual requirements, cam switches can be made with the switching angles given in table 132.

Table 127. Connection angles

Group		A0	A1	A2	A3	Maximum number of handle positions
Connection angle	30°	•	•	•	•	12
	45°	•	•	•		8
	60°	•	•	•	•	6
	90°	•	•	•	•	4

Special stops are used to fix proper positions. Switching elements, driving mechanism and a rear plate (mounting plate) are connected into one unit with insulating bolts.

Special versions of cam switches can have more than 12 switching elements.

SUB-ASSEMBLIES

Front plate

Complete front plate consists of:

- a front plate with a place with black frame for a text; - an indicating plate cover (transparent),
- indicating plate (under the cover, standard version is white with black signs).

According to requirements, this plate can be black, yellow or silver.

HANDLE

The handle is used to control the switch. Black is a standard colour. According special to requirements, the handles can be supplied in red colour.

Table 128. Handle types



Group	A0	A1	A2	A3
	R012 red R014 black (standard)	R112 red R114 black (standard)	R212 red R214 black (standard)	R312 red R314 black (standard)
		R122 red R124 black	R222 red R224 black	R322 red R324 black

Table 129. Technical data

Parameter		Switch type												
		4G10	4G16	4G25	4G40	4G63	4G80	4G100	4G200	4G400	4G630	4G800	4G1200	
Rated insulation voltage U_i	V	690	690	690	690	690	690	690	690	690	690	690	690	
Rated impulse withstand voltage U_{imp}	kV	4	4	4	6	6	6	6	8	8	8	8	8	
Rated thermal current I_{th}	A	16	20	25	50	63	80	125	200	400	630	800	1200	
Short-circuit protection Rated breaking capacity of fuse links with high breaking capacity	10 kA _{sk}	A	–	25	25	50	63	80	125	200	400	630	2x400	2x630
	25 kA _{sk}	A	–	25	25	50	63	80	125	160	315	500	2x400	2x630
	40 kA _{sk}	A	–	25	25	50	63	80	125	160	315	400	500	2x400
	63 kA _{sk}	A	–	25	25	36	50	63	100	160	250	355	400	630
	75 kA _{sk}	A	–	25	25	36	50	63	100					
Mechanical durability (number of cycles)		3x10 ⁶	3x10 ⁶	3x10 ⁶	3x10 ⁶	3x10 ⁶	3x10 ⁶	3x10 ⁶	2x10 ⁵	2x10 ⁵	2x10 ⁵	2x10 ⁵	2x10 ⁵	
Terminal bolts Maximum cross-section of connecting conductors	mm ²	M3 2 x 2,5	M4 2 x 4	M4 2 x 6	M5 2 x 10	M5 2 x 10	M6 25	2 x M6 50	M6 –	M10 –	M12 –	M16 –	M16 –	
Short duration load capacity	1 s	A	220	430	690	920	1600	1600	2600	3300	6500	9500	12000	18000
	10 s	A	70	145	240	290	600	650	850	1100	2000	3000	4000	6100
	30 s	A	40	90	160	200	375	400	500	640	1200	1800	2400	3500
	60 s	A	30	75	125	155	285	300	360	460	850	1250	1600	2450
Breaking capacity	660 V - $\cos\phi = 0,65$	A	–	190	–	–	–	–	–	640	–	–	–	–
	660 V - $\cos\phi = 0,35$	A	–	–	250	490	500	500	650	–	–	–	–	–
	600 V - $\cos\phi = 0,35$	A	–	200	260	500	610	610	–	–	–	–	–	–
	500 V - $\cos\phi = 0,35$	A	100 ¹⁾	–	–	–	–	–	900	900	–	–	–	–
	500 V - $\cos\phi = 0,75$	A	–	–	–	–	–	–	–	–	1100	1100	1200	1800
Switch disconnectors	3 x 220 V~	kW	5,2	7	9	14	23	29	37	72	150	150	150	150
Utilization category AC2	3 x 380 V~	kW	9	12,5	15,5	24	39	50	63	125	260	260	260	260
Rated power of three-phase loads	3 x 500 V~	kW	11,8	17	20	33	52	66	84	165	340	340	340	340
	3 x 660 V~	kW	15,5	22	27	43	69	86	110	210	400	400	400	400
Switch disconnectors for motors	3 x 220 V~	kW	3	4,5	7,5	12,5	18,5	21	–	27,5	27,5	27,5	27,5	27,5
Utilization category AC3, AC23	3 x 380 V~	kW	5	8	13	21	32	37	–	47	47	47	47	47
Rated power of three-phase motors	3 x 500 V~	kW	6	11	17	27	42	48	–	62	62	62	62	62
	3 x 660 V~	kW	6	11	17	27	55	60	–	80	80	80	80	80
Switch disconnectors for motors	3 x 220 V~	kW	–	–	–	–	–	–	27,5	27,5	27,5	27,5	27,5	27,5
Utilization category AC23	3 x 380 V~	kW	–	–	–	–	–	–	47	47	47	47	47	47
Rated power of three-phase motors	3 x 500 V~	kW	–	–	–	–	–	–	62	62	62	62	62	62
	3 x 660 V~	kW	–	–	–	–	–	–	80	80	80	80	80	80
Switch disconnectors for motors, category of utility AC3, AC23 (30 connections/h).	110 V~	kW	0,8	1,3	2,1	3,6	5,3	6	–	–	–	–	–	–
Rated power of one-phase (dipolar) motors.	220 V~	kW	1,7	2,6	4,3	7,2	10,6	12,1	–	–	–	–	–	–
	380 V~	kW	2,8	4,6	7,5	12	18,5	21,1	–	–	–	–	–	–
Auxiliary switch disconnectors	110 V~	A	11	20	25	50	63	72	–	–	–	–	–	–
Utilization category AC14	220 V~	A	8	20	25	40	50	50	–	–	–	–	–	–
Rated switching current I_e (1 pole)	380 V~	A	3,5	16	20	40	45	45	–	–	–	–	–	–
	660 V~	A	2,5	8	8,5	10	10	10	–	–	–	–	–	–
Type of operation	–	Continuous duty												

1) - $\cos\phi = 0,65$

BREAKING CAPACITY FOR DIRECT CURRENT

Breaking capacity for direct current operation depends on current intensity, voltage and inductance.

Time constant $T = L/R$ represents inductance values in a current circuit.

$T = 1 \text{ ms}$ – active power or lightly inductive power predominates, for example resistance furnaces.

$T = 15 \text{ ms}$ – inductive power predominates, for example relay coils. For direct current and voltage above 60 V, switch contacts must be connected in parallel to obtain higher breaking capacity.

Table 130. Rated breaking capacity of one contact

Switch type	Rated breaking capacity of one contact											
	24V		60V		110V		220V		440V		600V	
	T = 1ms	T = 15ms	T = 1ms	T = 15ms	T = 1ms	T = 15ms	T = 1ms	T = 15ms	T = 1ms	T = 15ms	T = 1ms	T = 15ms
4G10	40	40	40	20	17	3	1,1	0,5	0,5	0,2	0,5	0,1
4G16	100	100	38	18	5,5	3	0,95	0,4	0,5	0,25	0,3	0,2
4G25	100	100	38	18	5,5	3	0,95	0,4	0,5	0,25	0,3	0,2
4G40	252	252	95	40	15	3,5	1,2	0,4	0,6	0,25	0,45	0,2
4G63	252	252	95	40	15	3,5	1,2	0,4	0,6	0,25	0,45	0,2
4G100	800	800	400	400	35	7,5	2,5	0,75	0,9	0,3	0,5	0,25

Table 136 shows a number of contacts which can be connected in series for rated making currents at specific constant voltages for category of utility DC 1.

Table 131. Number of contacts connected in series

Switch type	Number of contacts connected in series			
	110V	220V	440V	600V
4G10	1	3	6	8
4G16	2	4	6	9
4G25	2	4	6	9
4G40	2	3	6	9
4G63	2	4	6	9
4G100	2	3	6	–

DC1 - main noninductive or low voltage load
 $T = 1 \text{ ms}$ breaking capacity $I = 1,5 I_n$

Note: Breaking capacity for a 4G25 switch with two contacts connected in series is 2A at 220V; $T = 15 \text{ ms}$. In table 137 the rated making current values (I_e) for category of utility DC 11 (according to EC 337-1, 337-1A) have been shown.

Table 132. Rated switching current

Switch type	Rated switching current I_e [A]					
	24V	60V	110V	220V	440V	600V
4G10	10	2	1	0,27	0,16	0,14
4G16	20	2,2	1	0,3	0,22	0,16
4G25	25	2,2	1	0,3	0,22	0,16
4G40	50	5	2	0,4	0,23	0,2
4G63	63	5	2	0,4	0,23	0,2

SWITCHING PROGRAMS

Switching program	Diagram number	Page	
Switch disconnectors with "0" (0-1) position			
1-pole	90	167	
2-pole	91		
3-pole	10		
multi-pole	92		
	100		
	528		
	659		
Switch disconnectors with quick-connecting contacts (0-1)			
with 30° contact lead	1-pole	270	167
	2-pole	271	
	3-pole	63	
with 30° contact lead on three contacts and 60° on one contact	4-pole	272	
with 30° contact lead on three contacts and 60° on two contacts	5-pole	273	
with 30° contact lead	6-pole	274	
Switches with "0" (1-0-2) position			
1-pole	51	168	
2-pole	52		
3-pole	53		
multi-pole	75		
	76		
	77		
	78		
	79		
	80		
81			
Switches for current transformers (1-2)			
	57	168	
Switches without "0" (1-2) position			
1-pole	54	169	
2-pole	55		
3-pole	56		
multi-pole	69		
	70		
	71		
	72		
	73		
	74		
62			
Multiposition switches with "0" (0-1-2...) position			
1-pole	3-position	107	170
	4-position	108	
	5-position	109	
	6-position	110	

Switching program	Diagram number	Page	
Multiposition switches with "0" (0-1-2...) position			
1-pole	7-position	111	170
	8-position	112	
	9-position	113	
	10-position	114	
	11-position	115	
	12-position	116	
2-pole	3-position	123	171
	4-position	124	
	5-position	125	
	6-position	126	
	7-position	127	
	8-position	128	
3-pole	9-position	129	172
	10-position	130	
	11-position	131	
	12-position	132	
	3-position	135	
	4-position	136	
multi-pole	5-position	137	172
	6-position	138	
	7-position	139	
	8-position	140	
	3-position	145	
	4-position	146	
multi-pole	5-position	147	173
	6-position	148	
	3-position	151	
	4-position	152	
	5-position	153	
	3-position	156	
1-pole	4-position	157	174
	5-position	158	
	3-position	160	
	4-position	161	
	3-position	163	
	4-position	164	
Multiposition switches without "0" position			
1-pole	3-position	82	174
	4-position	83	
	5-position	84	
	6-position	85	
	7-position	101	
	8-position	102	
	9-position	103	
	10-position	104	
	11-position	105	
	12-position	106	

Switching program		Diagram number	Page	
Multiposition switches without "0" position				
2-pole	3-position	86	177	
	4-position	87		
	5-position	88		
	6-position	89		
	7-position	117		
	8-position	118		
	9-position	119		
	10-position	120		
	11-position	121		
	12-position	122		176
3-pole	3-position	93	176	
	4-position	94		
	5-position	95		
	6-position	96		
	7-position	133		
	8-position	134		
	3-position	141		177
	4-position	142		
multi-pole	5-position	143	176	
	6-position	144		
	3-position	149	177	
	4-position	150		
	3-position	154		
	4-position	155		
	3-position	159		
	3-position	162		
Switchgroups with "0" position				
1-pole	2-group.	251	178	
	3-group.	254		
2-pole	2-group.	252		
	3-group.	255		
3-pole	2-group.	253		
	3-group.	256		
Serial switches				
1-pole		257	178	
2-pole		258	179	
3-pole		259		
Serial-parallel switches				
2-pole		260	179	
Measurement switches for voltage and current				
Ammeter switches				
phase measurement	L1-L2-L3	58	179	
phase measurement	0-1-2-3	97		
phase measurement with grounding	0-1-2-3	98		
Serial-parallel switches				
3 phase-to-phase voltages + phase voltage		60	179	

Switching program		Diagram number	Page	
Voltmeter switches without "0" position				
3 phase voltages		68	180	
3 phase-to-phase voltages		67		
3 phase-to-phase voltages + 3 phase voltages		66		
Switches with an automatic return to initial position				
switch with a function of left - right pushbuttons switch with "0" position (1-0-2) return to "0" from both sides		210	180	
1-pole		201		
2-pole		202		
3-pole		203		
Switches without "0" position				
1 normally closed contact + 1 normally open contact		204	181	
2 normally closed contacts + 2 normally open contacts		205		
3 normally closed contacts + 3 normally open contacts		206		
to control a contactor – 1 normally open contact (turn right) and 1 normally closed contact (turn left)		207		
1 normally open contact and 1 normally closed contact, when turning left and right		208		
2 normally open contacts and 2 normally closed contacts, when turning left and right		209		
Switch disconnectors for motor controlling, Star-delta switch disconnectors				
basic version		12		181
Y/Δ back from Y to 0		28		
with counter-current braking back from Y to 0		29	182	
as a voltage switch		30		
for operation with contactor		31		
bidirectional (left-right)		21		
Switch disconnectors in a Dahlander's system				
dipolar Δ-0-YY		13	182	
dipolar 0-Δ-YY		19		
dipolar bidirectional YY-Δ-0-Δ-YY		20		
dipolar and contactor controlling		32		
Switch disconnectors for two-winding motors				
0-1-2		22	183	
bidirectional		23		
to control the contactors		33		
Switch disconnectors for three-speed motors				
2 windings 0-Δ-YY-Y (with 3 speeds in a Dahlander's system)		34	184	
2 windings 0-Δ-YY-Y (1 and 2 speeds in a Dahlander's system)		35		
2 windings 0-Δ-YY-Y (2 and 3 speeds in a Dahlander's system)		36		
Reversing switches				
2-pole		24	184	
2-pole, return to "0" position		25		
3-pole		11		
3-pole, return to "0" position		26		
to control a contactor		27		
starting switches for 1-phase motors		15		

AN ORDER EXAMPLE

4G25 - 10 - U S5 R112

switch type determined according to the rated current, selection in accordance with table 1

diagram number specified in the switching program

version:
U- switch to be built-in
OU- switch to be mounted in a housing
PK- switch in a plastic case

special version, its symbol can be added to the description of type

knob and handle version and colour according to table 3

NOTES:

- every order on devices for rated current 100A requires arrangements with the manufacturer related to the technical details and delivery date.
- devices in PK housings can be made only for those switching programs which require not more than four segments (protection class IP 55/IP 65).
EXPRES SERVICE 24 h or 48 h - There is the ability to perform cam switches in 24 or 48 h (additional fee)

STANDARD CONNECTION DIAGRAMS

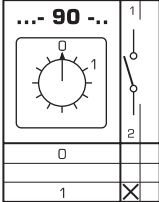
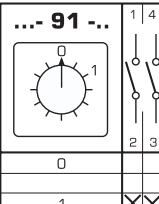
Diagram number	Number of poles	Rated switching current	Rated voltage	Number of packs	Symbol Article No.	Handle	Protection degree IP from the front	Maximum conductor cross-section [mm ²]	Installation
Switch disconnecter with "0" (0-1) position									
	1	10	690	1	4G10-90-U 63-840390-011	R014	IP40	2 x 2,5	to be mounted behind the panel
	1	16	690	1	4G16-90-U 63-840390-021	R114	IP40	2 x 4	to be mounted behind the panel
	1	25	690	1	4G25-90-U 63-840390-031	R114	IP40	2 x 6	to be mounted behind the panel
	1	10	690	1	4G10-90-PK 63-840392-011	R014	IP55	2 x 2,5	in a housing
	1	25	690	1	4G10-90-PKIP65 63-840392-111	R114	IP65	2 x 6	in a housing
	1	16	690	1	4G16-90-PK 63-840392-021	R114	IP55	2 x 4	in a housing
	1	25	690	1	4G25-90-PK 63-840392-031	R114	IP55	2 x 6	in a housing
	2	10	690	1	4G10-91-U 63-840393-011	R014	IP40	2 x 2,5	to be mounted behind the panel
	2	16	690	1	4G16-91-U 63-840393-021	R114	IP40	2 x 4	to be mounted behind the panel
	2	10	690	1	4G10-91-PK 63-840395-011	R014	IP55	2 x 2,5	in a housing
	2	25	690	1	4G10-91-PKIP65 63-840395-111	R114	IP65	2 x 6	in a housing
	2	16	690	1	4G16-91-PK 63-840395-021	R114	IP55	2 x 4	in a housing
	2	25	690	1	4G25-91-PK 63-840395-031	R114	IP55	2 x 6	in a housing

* See dimensions on pages 185-188

Diagram number	Number of poles	Rated switching current	Rated voltage	Number of packs	Symbol Article No.	Handle	Protection degree IP from the front	Maximum conductor cross-section [mm ²]	Installation
Switch disconnector with "0" (0-1) position									
	3	10	690	2	4G10-10-U 63-840304-011	R014	IP40	2 x 2,5	to be mounted behind the panel
	3	16	690	2	4G16-10-U 63-840304-021	R114	IP40	2 x 4	to be mounted behind the panel
	3	25	690	2	4G25-10-U 63-840304-031	R114	IP40	2 x 6	to be mounted behind the panel
	3	40	690	2	4G40-10-U 63-840304-041	R214	IP40	2 x 10	to be mounted behind the panel
	3	63	690	2	4G63-10-U 63-840304-051	R214	IP40	2 x 10	to be mounted behind the panel
	3	80	690	2	4G80-10-U 63-840304-061	R214	IP40	25	to be mounted behind the panel
	3	10	690	2	4G10-10-PK 63-840306-011	R014	IP55	2 x 2,5	in a housing
	3	10	690	2	4G10-10-PK IP65 63-840306-111	R014	IP65	2 x 2,5	in a housing
	3	16	690	2	4G16-10-PK 63-840306-021	R114	IP55	2 x 4	in a housing
	3	25	690	2	4G25-10-PK 63-840306-031	R114	IP55	2 x 6	in a housing
	3	40	690	2	4G40-10-PK 63-840306-041	R214	IP55	2 x 10	in a housing
	3	63	690	2	4G63-10-PK 63-840306-051	R214	IP55	2 x 10	in a housing
	3	80	690	2	4G80-10-PK 63-840306-061	R214	IP55	25	in a housing
		4	10	690	2	4G10-92-U 63-840396-011	R014	IP40	2 x 2,5
4		16	690	2	4G16-92-U 63-840396-021	R114	IP40	2 x 4	to be mounted behind the panel
4		25	690	2	4G25-92-U 63-840396-031	R114	IP40	2 x 6	to be mounted behind the panel
4		40	690	2	4G40-92-U 63-840396-041	R214	IP40	2 x 10	to be mounted behind the panel
4		63	690	2	4G63-92-U 63-840396-051	R214	IP40	2 x 10	to be mounted behind the panel
4		80	690	2	4G80-92-U 63-840396-061	R214	IP40	25	to be mounted behind the panel
4		10	690	2	4G10-92-PK 63-840398-011	R014	IP55	2 x 2,5	in a housing
4		10	690	2	4G10-92-PK IP65 63-840398-111	R014	IP65	2 x 2,5	in a housing
4		16	690	2	4G16-92-PK 63-840398-021	R114	IP55	2 x 4	in a housing
4		25	690	2	4G25-92-PK 63-840398-031	R114	IP55	2 x 6	in a housing
4		40	690	2	4G40-92-PK 63-840398-041	R214	IP55	2 x 10	in a housing
4		63	690	2	4G63-92-PK 63-840398-051	R214	IP55	2 x 10	in a housing
4		80	690	2	4G80-92-PK 63-840398-061	R214	IP55	25	in a housing

* See dimensions on pages 185-188

Diagram number	Number of poles	Rated switching current	Rated voltage	Number of packs	Symbol Article No.	Handle	Protection degree IP from the front	Maximum conductor cross-section [mm ²]	Installation
„Mains-unit” switch (1-O-2)									
	1	10	690	1	4G10-51-U 63-840338-011	R014	IP40	2 x 2,5	to be mounted behind the panel
	1	10	690	1	4G10-51-PK 63-840340-011	R014	IP55	2 x 2,5	in a housing
	1	10	690	1	4G10-51-PK IP65 63-840340-111	R014	IP65	2 x 2,5	in a housing
	2	10	690	2	4G10-52-U 63-840341-011	R014	IP40	2 x 2,5	to be mounted behind the panel
	3	10	690	3	4G10-53-U 63-840343-011	R014	IP40	2 x 2,5	to be mounted behind the panel
	3	16	690	3	4G16-53-U 63-840343-021	R114	IP40	2 x 4	to be mounted behind the panel
	3	25	690	3	4G25-53-U 63-840343-031	R114	IP40	2 x 6	to be mounted behind the panel
	3	40	690	3	4G40-53-U 63-840343-041	R214	IP40	2 x 10	to be mounted behind the panel
	3	63	690	3	4G63-53-U 63-840343-051	R214	IP40	2 x 10	to be mounted behind the panel
	3	80	690	3	4G80-53-U 63-840343-061	R214	IP40	25	to be mounted behind the panel
	3	10	690	3	4G10-53-PK 63-840345-011	R014	IP55	2 x 2,5	in a housing
	3	10	690	3	4G10-53-PK IP65 63-840345-111	R014	IP65	2 x 2,5	in a housing
	3	16	690	3	4G16-53-PK 63-840345-021	R114	IP55	2 x 4	in a housing
	3	25	690	3	4G25-53-PK 63-840345-031	R114	IP55	2 x 6	in a housing
	3	40	690	3	4G40-53-PK 63-840345-041	R214	IP55	2 x 10	in a housing
	3	63	690	3	4G63-53-PK 63-840345-051	R214	IP55	2 x 10	in a housing
	3	80	690	3	4G80-53-PK 63-840345-061	R214	IP55	25	in a housing
„Rotation direction change” switch (L-O-P)									
	3	10	690	3	4G10-11-U 63-840307-011	R014	IP40	2 x 2,5	to be mounted behind the panel
	3	16	690	3	4G16-11-U 63-840307-021	R114	IP40	2 x 4	to be mounted behind the panel
	3	25	690	3	4G25-11-U 63-840307-031	R114	IP40	2 x 6	to be mounted behind the panel
	3	40	690	3	4G40-11-U 63-840307-041	R214	IP40	2 x 10	to be mounted behind the panel
	3	63	690	3	4G63-11-U 63-840307-051	R214	IP40	2 x 10	to be mounted behind the panel
	3	80	690	3	4G80-11-U 63-840307-061	R214	IP40	25	to be mounted behind the panel

* See dimensions on pages 185-188

Diagram number	Number of poles	Rated switching current	Rated voltage	Number of packs	Symbol Article No.	Handle	Protection degree IP from the front	Maximum conductor cross-section [mm ²]	Installation
----------------	-----------------	-------------------------	---------------	-----------------	--------------------	--------	-------------------------------------	--	--------------

„Rotation direction change” switch (L-O-P)

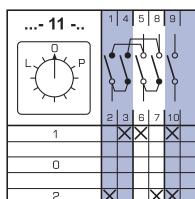

...	11	3	10	690	3	4G10-11-PK 63-840309-011	R014	IP55	2 x 2,5	in a housing
		3	10	690	3	4G10-11-PKIP65 63-840309-111	R014	IP65	2 x 2,5	in a housing
	1	3	16	690	3	4G16-11-PK 63-840309-021	R114	IP55	2 x 4	in a housing
	0									
	2	3	25	690	3	4G25-11-PK 63-840309-031	R114	IP55	2 x 6	in a housing
		3	40	690	3	4G40-11-PK 63-840309-041	R214	IP55	2 x 10	in a housing
		3	63	690	3	4G63-11-PK 63-840309-051	R214	IP55	2 x 10	in a housing
		3	80	690	3	4G80-11-PK 63-840309-06	R214	IP55	25	in a housing

„Star-delta” (Y-O-Δ) motor control switch

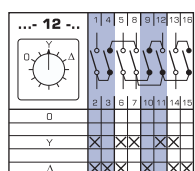

...	12	3	10	690	4	4G10-12-U 63-840310-011	R014	IP40	2 x 2,5	to be mounted behind the panel
		3	16	690	4	4G16-12-U 63-840310-021	R114	IP40	2 x 4	to be mounted behind the panel
	0	3	25	690	4	4G25-12-U 63-840310-031	R114	IP40	2 x 6	to be mounted behind the panel
	Y									
	Δ	3	40	690	4	4G40-12-U 63-840310-041	R214	IP40	2 x 10	to be mounted behind the panel
		3	63	690	4	4G63-12-U 63-840310-051	R214	IP40	2 x 10	to be mounted behind the panel
		3	80	690	4	4G80-12-U 63-840310-061	R214	IP40	25	to be mounted behind the panel
		3	10	690	4	4G10-12-PK 63-840591-011	R014	IP55	2 x 2,5	in a housing
		3	10	690	4	4G10-12-PKIP65 63-840591-111	R014	IP65	2 x 2,5	in a housing
		3	16	690	4	4G16-12-PK 63-840591-021	R114	IP55	2 x 4	in a housing
		3	25	690	4	4G25-12-PK 63-840591-031	R114	IP55	2 x 6	in a housing
		3	40	690	4	4G40-12-PK 63-840591-041	R214	IP55	2 x 10	in a housing
		3	63	690	4	4G63-12-PK 63-840591-051	R214	IP55	2 x 10	in a housing
		3	80	690	4	4G80-12-PK 63-840591-061	R214	IP55	25	in a housing

Voltmeter switch (L3L1, L2L3, L1L2 - 0 - L1N, L2N, L3N)

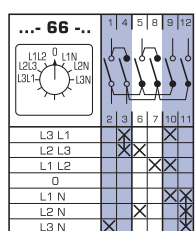

...	66	4	10	690	3	4G10-66-U 63-840360-011	R014	IP40	2 x 2,5	to be mounted behind the panel
-----	----	---	----	-----	---	----------------------------	------	------	---------	--------------------------------

Switch for forklift trucks(1-0-2)

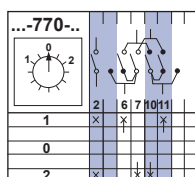

...	770	5	80	690	6	4G80-770-U 63-841838-061	R214	IP40	25	to be mounted behind the panel
-----	-----	---	----	-----	---	-----------------------------	------	------	----	--------------------------------

the contact (terminal 1-2) should be switched on in the control circuit coil of the contactor relay

* See dimensions on pages 185-188

Diagram number	Number of poles	Rated switching current	Rated voltage	Number of packs	Symbol Article No.	Handle	Protection degree IP from the front	Maximum conductor cross-section [mm ²]	Installation
Main (emergency) switch connectors									
	3	16	690	2	4G16-10-PK S6 63-241669-021	R114	IP55	2 x 4	in a housing
	3	16	690	2	4G16-10-OU S8 S25 63-241670-021	R114	IP40	2 x 4	mounting plate
	3	16	690	2	4G16-10-U S25 63-241671-021	R114	IP40	2 x 4	to be mounted behind the panel
	3	25	690	2	4G25-10-OU S8 S25 63-241672-031	R114	IP40	2 x 6	mounting plate
	3	25	690	2	4G25-10-PK S6 63-241673-031	R114	IP55	2 x 6	in a housing
	3	25	690	2	4G25-10-U S25 63-241674-031	R114	IP40	2 x 6	to be mounted behind the panel
	3	40	690	2	4G40-10-OU S8 S25 63-241675-041	R214	IP40	2 x 10	mounting plate
	3	40	690	2	4G40-10-PK S6 63-241676-041	R214	IP55	2 x 10	in a housing
	3	40	690	2	4G40-10-U S25 63-241677-041	R214	IP40	2 x 10	to be mounted behind the panel
	3	63	690	2	4G63-10-U S25 63-241678-051	R214	IP40	2 x 10	to be mounted behind the panel
3	80	690	2	4G80-10-U S6 63-241858-061	R214	IP40	25	to be mounted behind the panel	
Switches (1-2)									
	1	10	690	1	4G10-54-U 63-840346-011	R014	IP40	2 x 2,5	to be mounted behind the panel
	1	10	690	1	4G10-54-PK 63-840347-011	R014	IP55	2 x 2,5	in a housing
	1	10	690	1	4G10-54-PK IP65 63-840347-111	R014	IP65	2 x 2,5	in a housing
	2	10	690	2	4G10-55-U 63-840348-011	R014	IP40	2 x 2,5	to be mounted behind the panel
	2	10	690	2	4G10-55-PK 63-840350-011	R014	IP55	2 x 2,5	in a housing
	2	10	690	2	4G10-55-PK IP65 63-840350-111	R014	IP65	2 x 2,5	in a housing
	3	10	690	3	4G10-56-PK konfigurator	R014	IP40	2 x 2,5	in a housing
	4	10	690	4	4G10-69-U 63-840367-011	R014	IP40	2 x 2,5	to be mounted behind the panel

* Special versions S6 i S8 see on pages 190, S25 see on page 195

* See dimensions on pages 185-188

SWITCHING PROGRAMS

Switch disconnecter with "0" (0-1) position

Table 133.

Switching program	Diagram number
1-pole	90
2-pole	91
3-pole	10
multi-pole	92
	99
	100
	528
	659

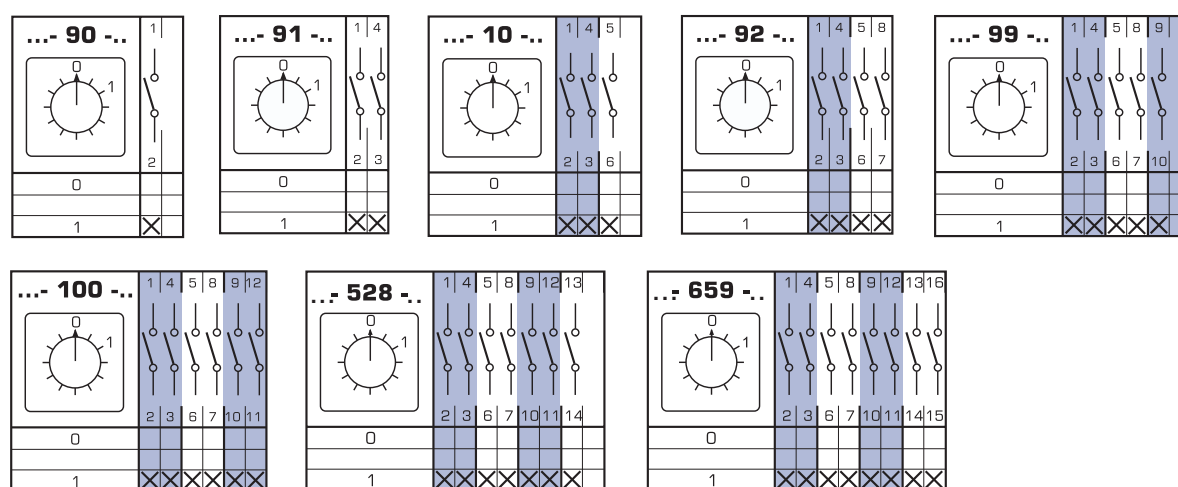

Switch disconnectors with quick-connecting contacts (0-1)

Table 134.

Switching program	Diagram number
with 30° contact lead 30°	1-pole 270
with 30° contact lead 30°	2-pole 271
with 30° contact lead 30°	3-pole 63
with 30° contact lead on three contacts and 60° on one contact	4-pole 272
with 30° contact lead on three contacts and 60° on two contacts	5-pole 273
with 30° contact lead 30°	6-pole 274

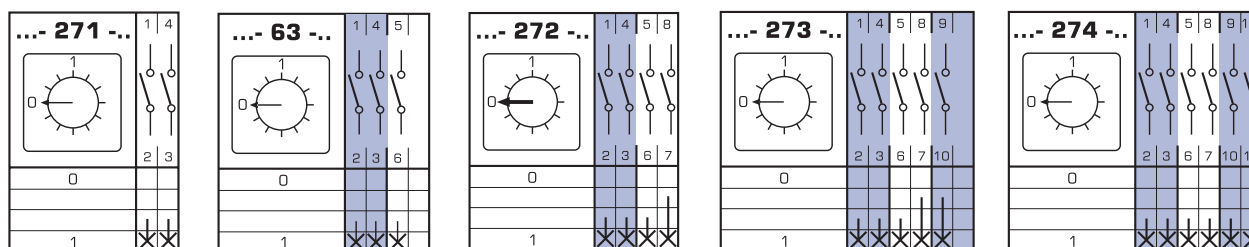
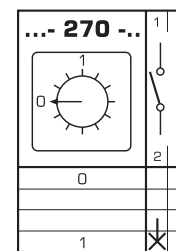

* See dimensions on pages 185-188

Switches with "0"(1-0-2) position

Switches for current transformers (1-2)

Table 135.

Switching program	Diagram number
1-pole	51
2-pole	52
3-pole	53
multi-pole	75
	76
	77
	78
	79
	80
	81

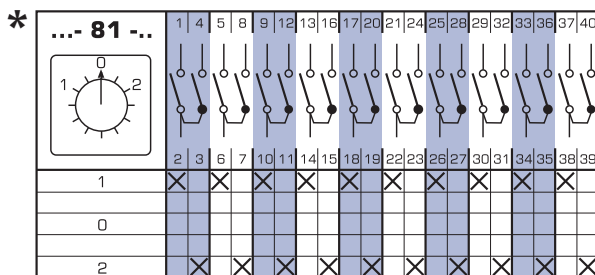
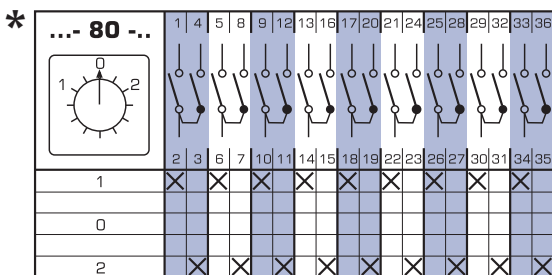
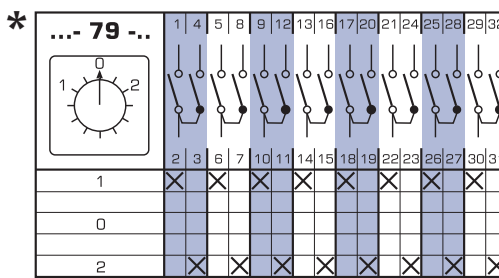
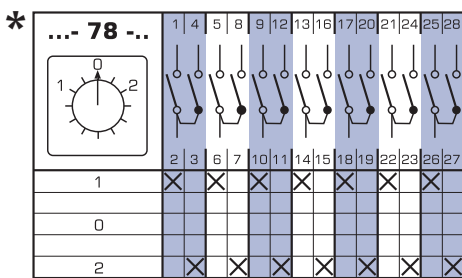
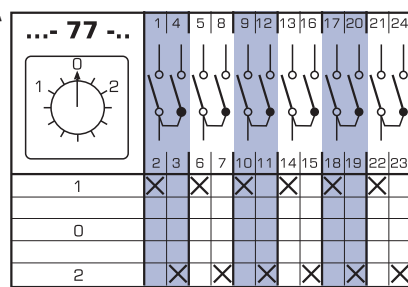
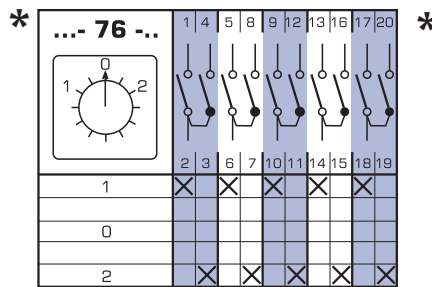
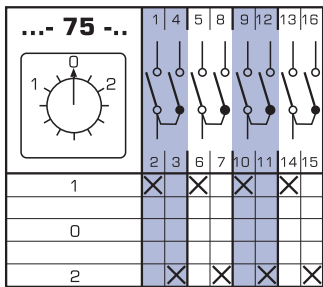
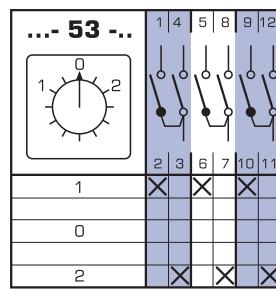
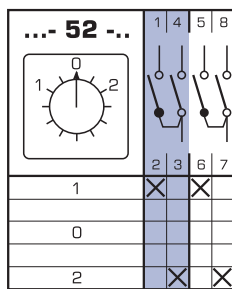
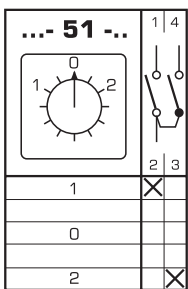
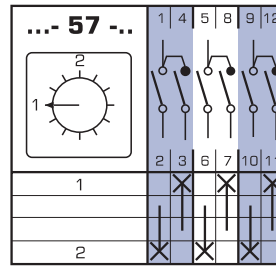

* Only in versions U, OU

* See dimensions on pages 185-188

SWITCHES WITHOUT "0"(1-2) POSITION

Table 136.

Switching program	Diagram number
1-pole	54
2-pole	55
3-pole	56
multi-pole	69
	70
	71
	72
	73
	74
	62

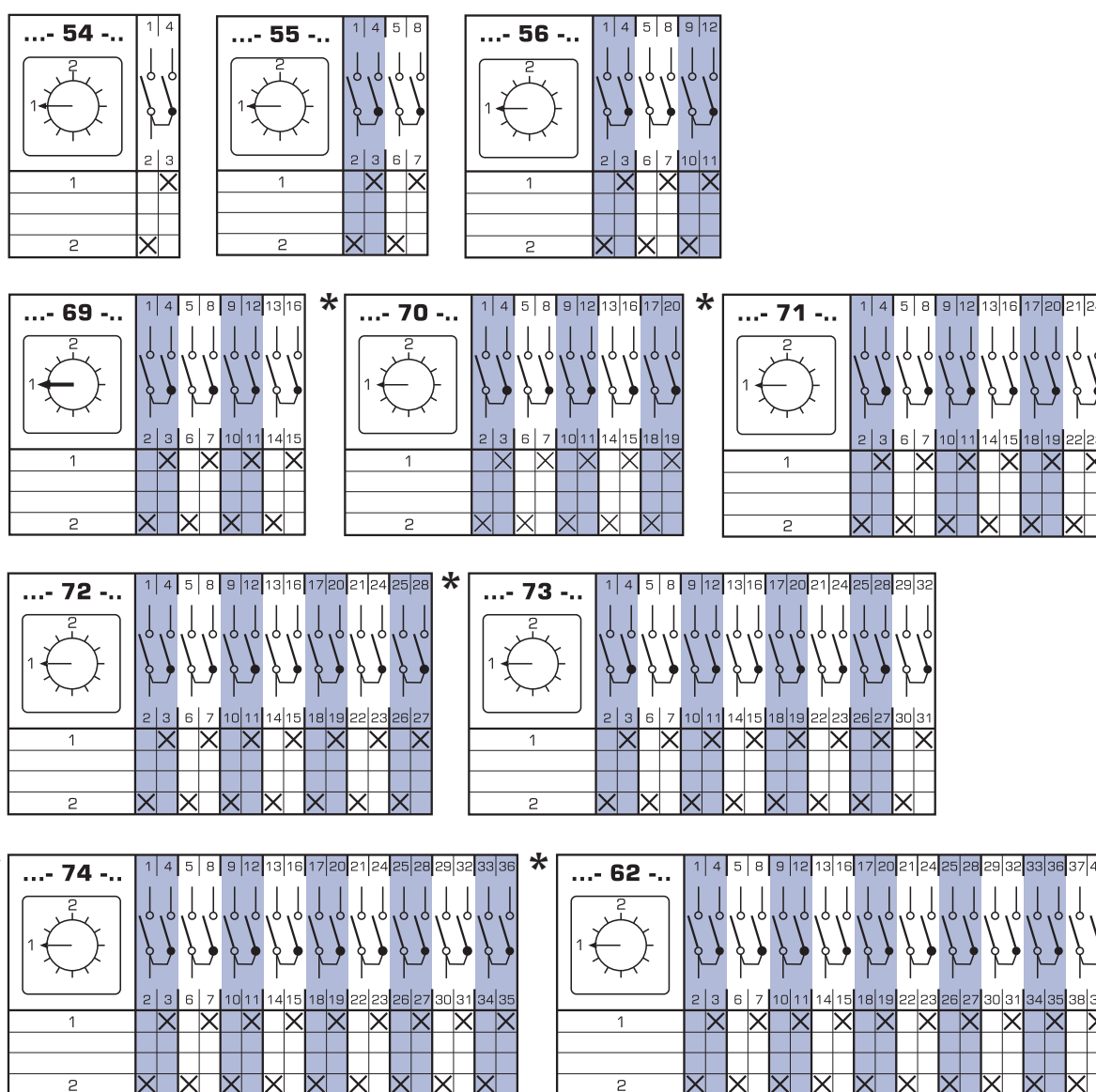

* Only in versions U, OU

* See dimensions on pages 185-188

Multiposition switches with "0" (0-1-2...) position

Table 137.

Switching program		Diagram number	
1-pole	3-position	107	
	4-position	108	
	5-position	109	
	6-position	110	
	7-position	111	
	8-position	112	
	9-position	113	
	10-position	114	
	11-position	115	
	12-position	116	
	2-pole	3-position	123
		4-position	124
5-position		125	
6-position		126	
7-position		127	
8-position		128	
9-position		129	
10-position		130	
11-position		131	
12-position		132	
3-pole	3-position	135	
	4-position	136	
	5-position	137	
	6-position	138	
	7-position	139	
	8-position	140	
	multi-pole	3-position	145
		4-position	146
5-position		147	
6-position		148	
3-position		151	
4-position		152	
5-position		153	
3-position		156	
4-position		157	
5-position		158	
3-position		160	
4-position		161	
3-position		163	
4-position		164	

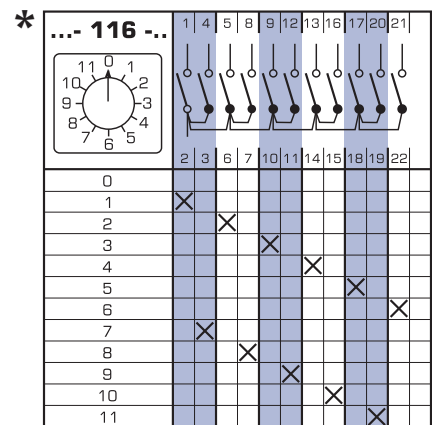
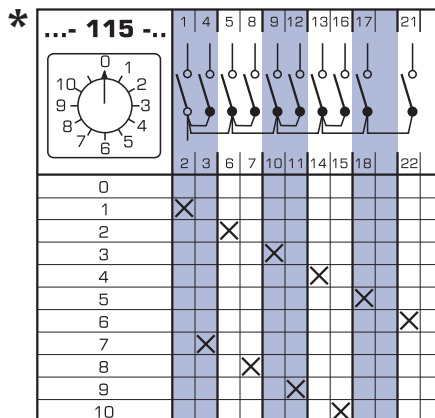
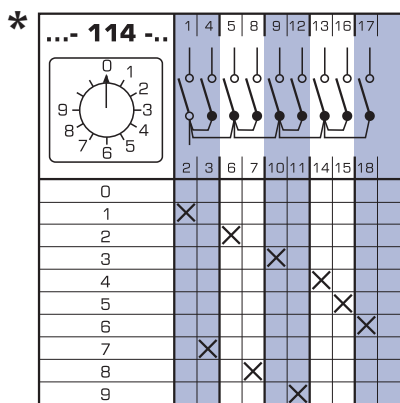
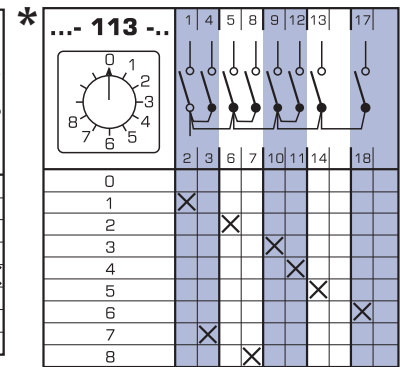
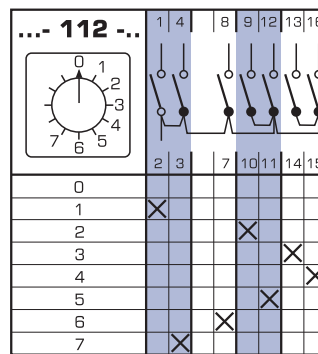
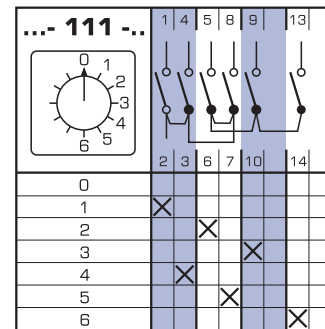
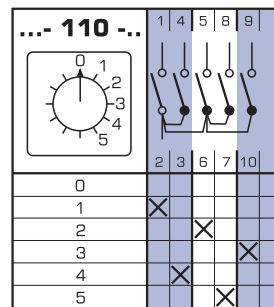
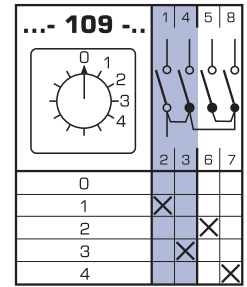
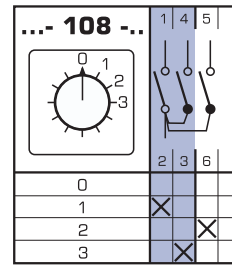
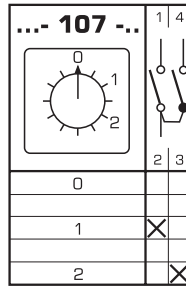

* Only in versions U, OU
 * See dimensions on pages 185-188

Multiposition switches with "0" (0-1-2...) position

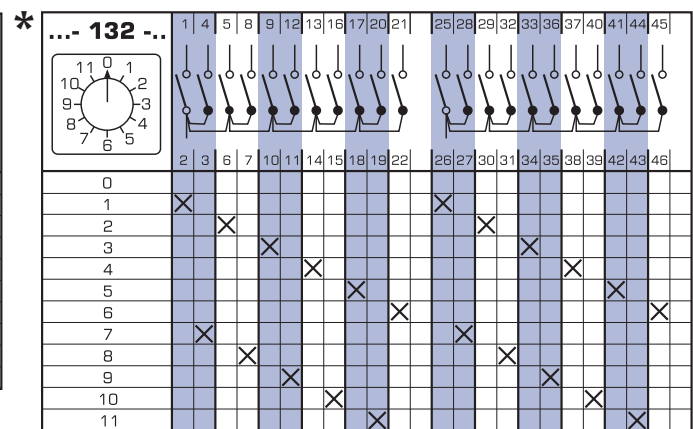
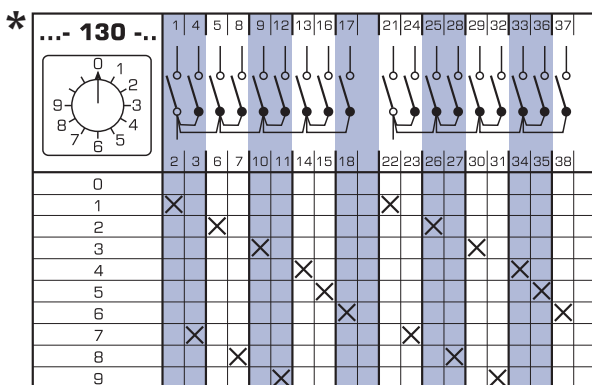
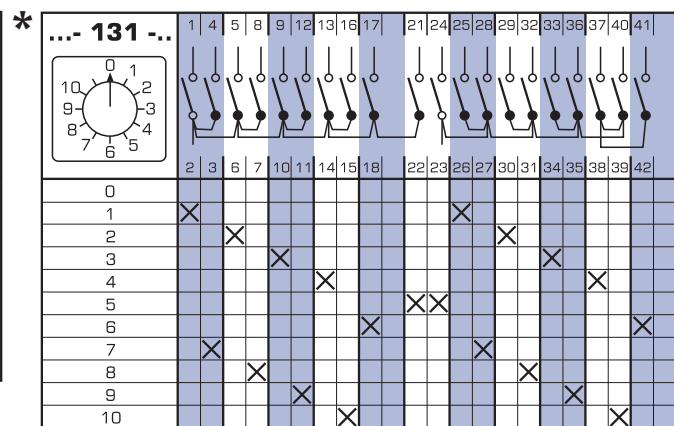
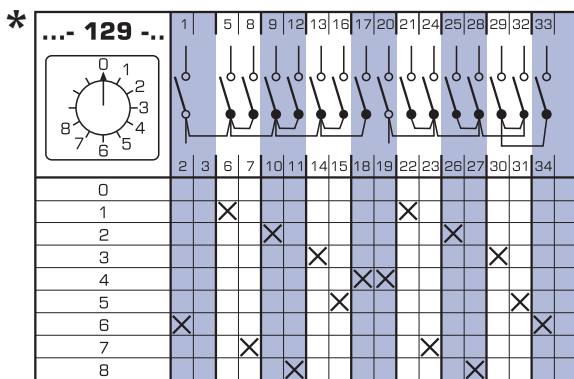
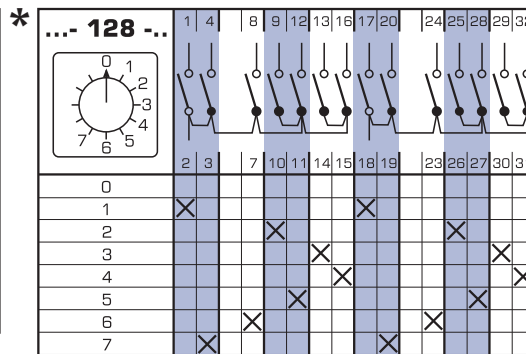
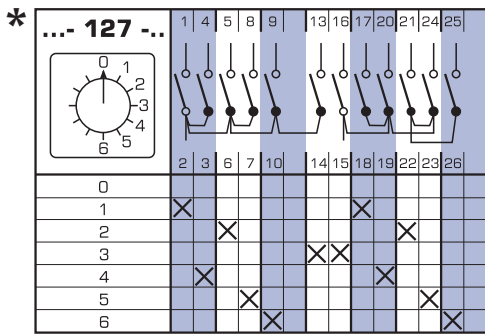
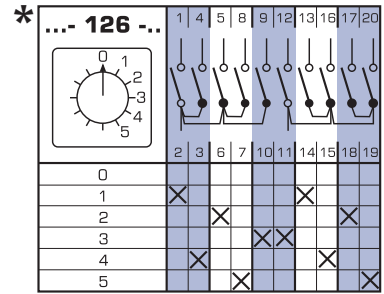
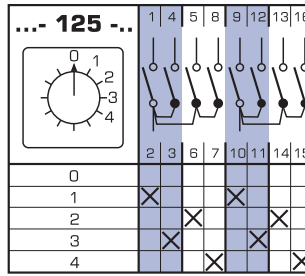
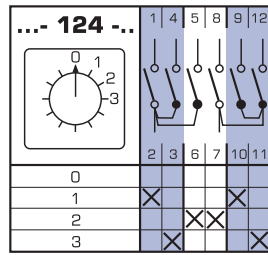
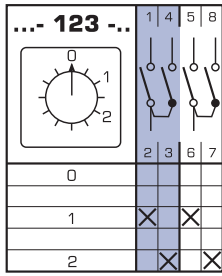

* Only in versions U, OU
 * See dimensions on pages 185-188

Multiposition switches with "0" (0-1-2...) position

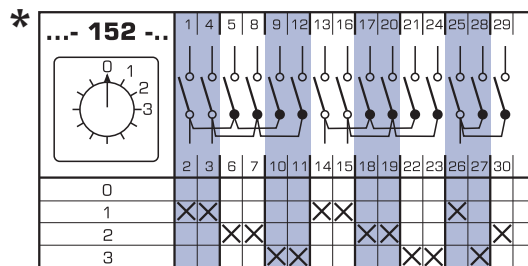
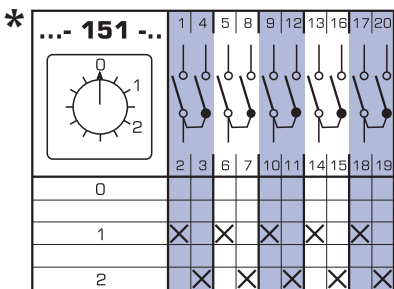
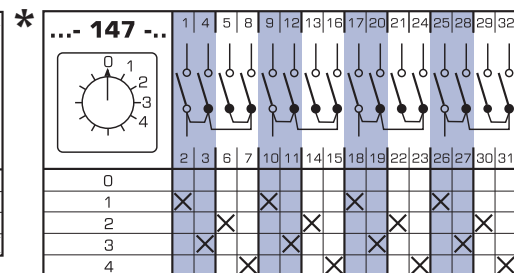
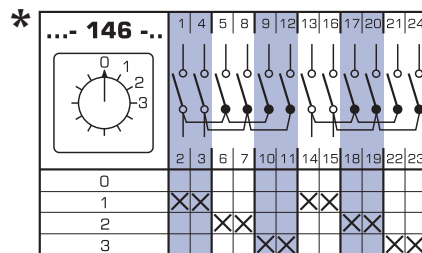
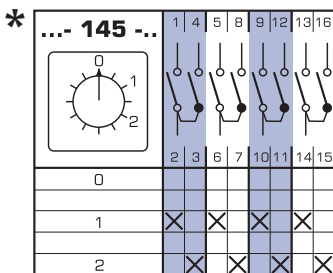
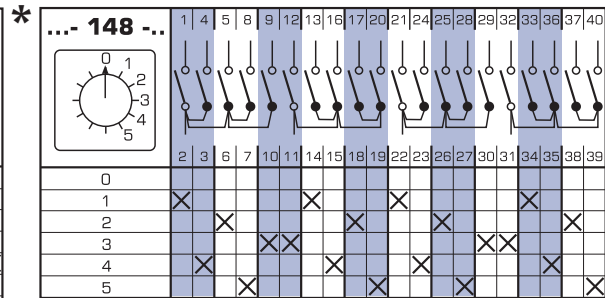
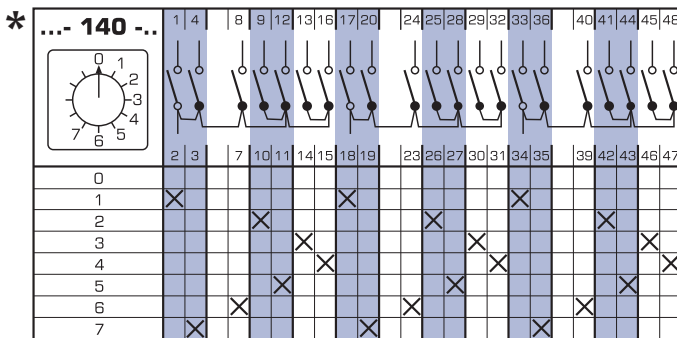
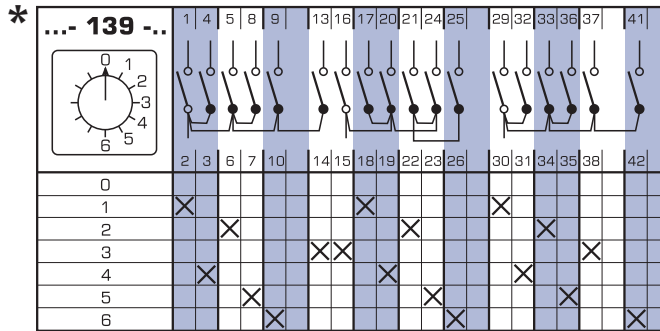
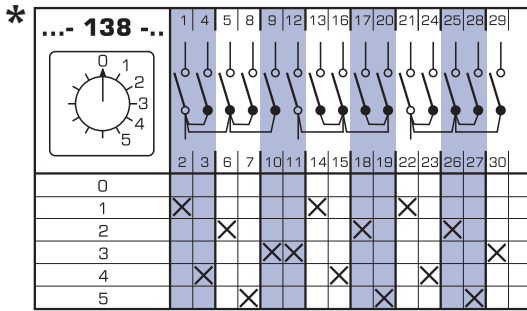
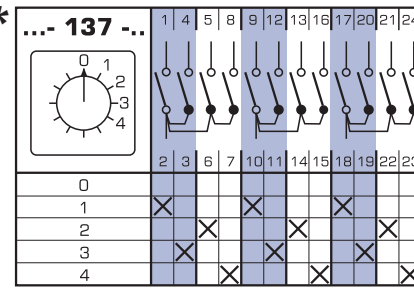
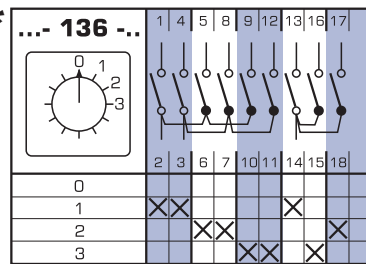
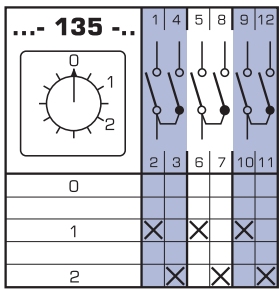

* Only in versions U, OU
* See dimensions on pages 185-188

Multiposition switches with "0" (0-1-2...) position

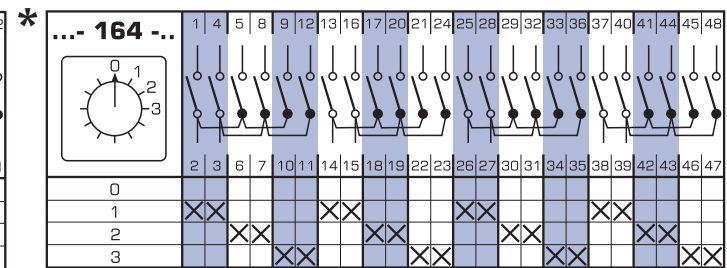
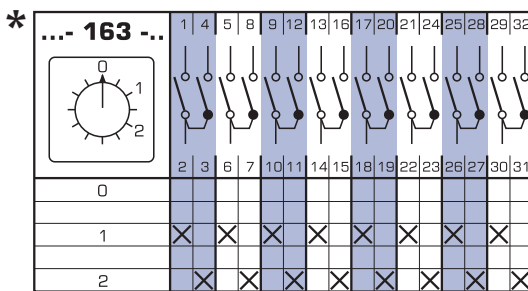
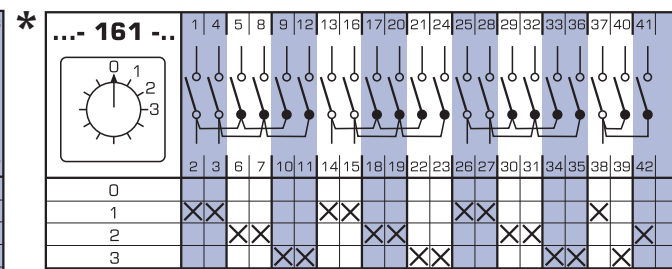
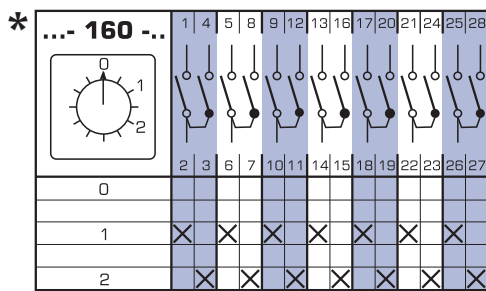
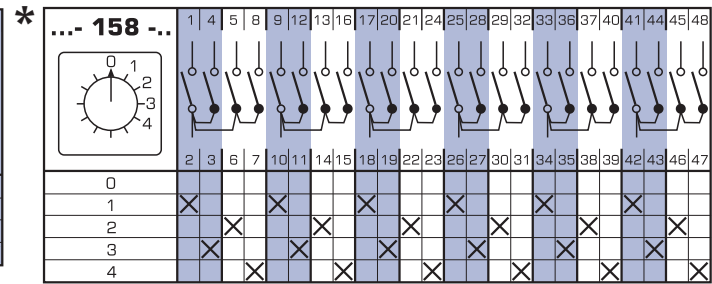
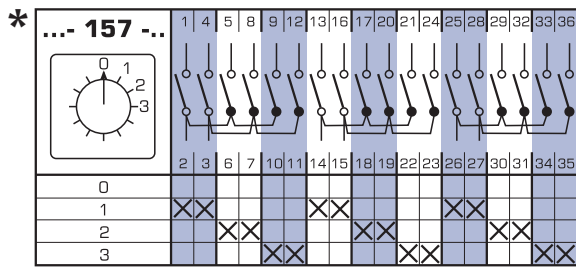
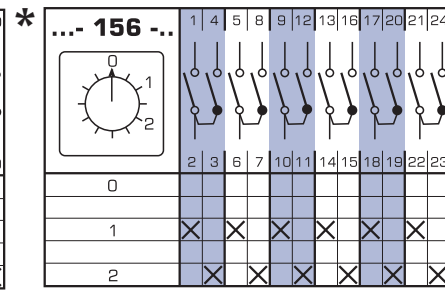
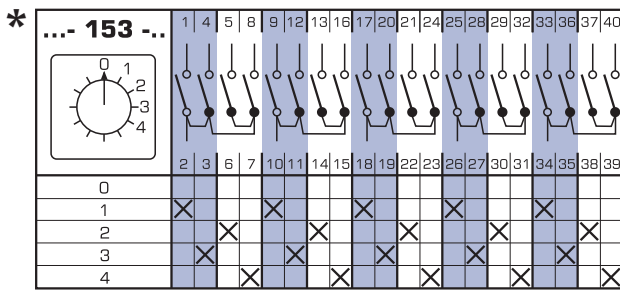

* Only in versions U, OU
 * See dimensions on pages 185-188

Multiposition switches without "0" position

Table 138.

Switching program	Diagram number		
1-pole	3-position	82	
	4-position	83	
	5-position	84	
	6-position	85	
	7-position	101	
	8-position	102	
	9-position	103	
	10-position	104	
	11-position	105	
	12-position	106	
	2-pole	3-position	86
		4-position	87
5-position		88	
6-position		89	
7-position		117	
8-position		118	
9-position		119	
10-position		120	
11-position		121	
12-position		122	
3-pole		3-position	93
		4-position	94
	5-position	95	
	6-position	96	
	7-position	133	
	8-position	134	
	multi-pole	3-position	141
		4-position	142
5-position		143	
6-position		144	
3-position		149	
4-position		150	
3-position		154	
4-position		155	
3-position		159	
3-position		162	

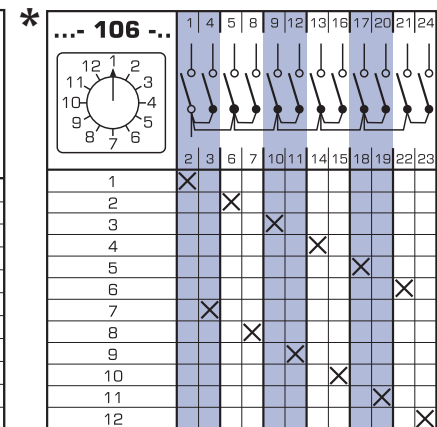
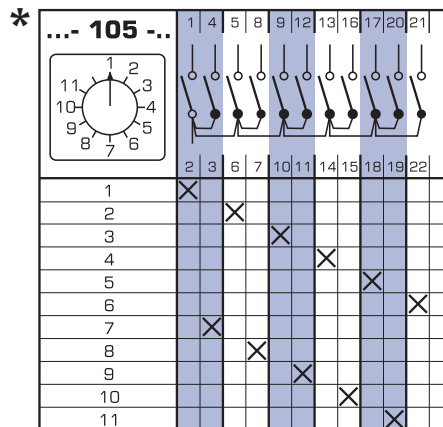
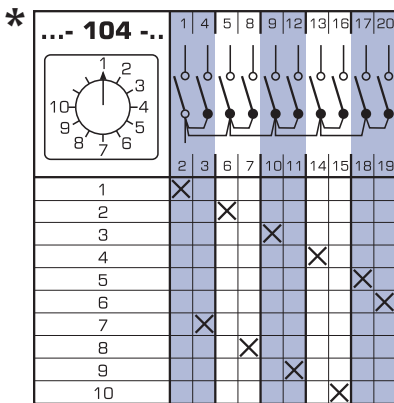
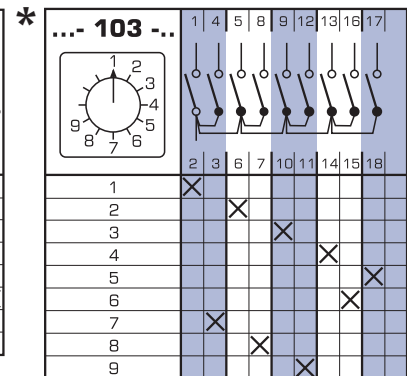
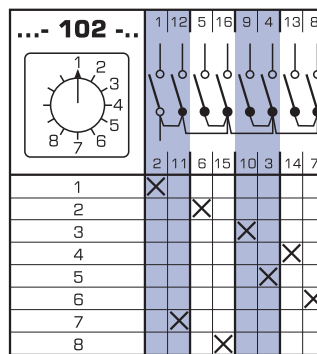
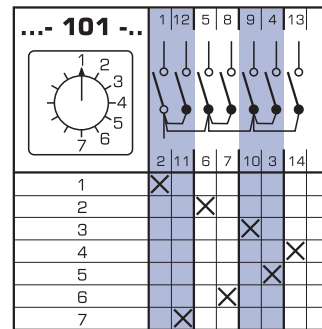
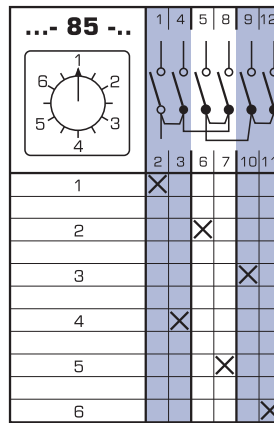
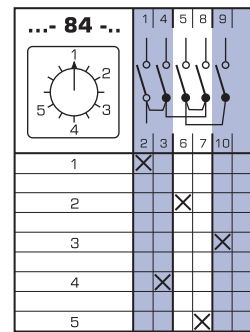
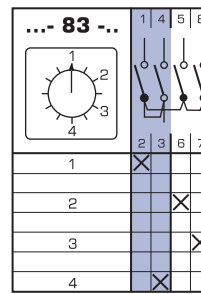
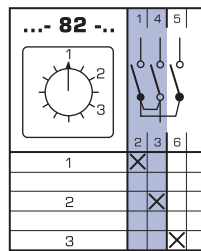

* Only in versions U, OU
* See dimensions on pages 185-188

Multiposition switches without "0" position

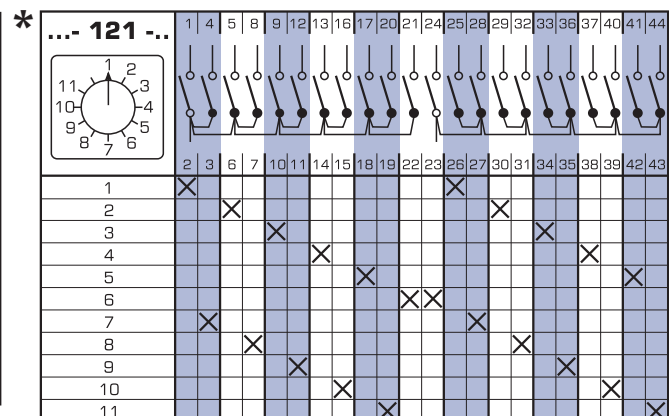
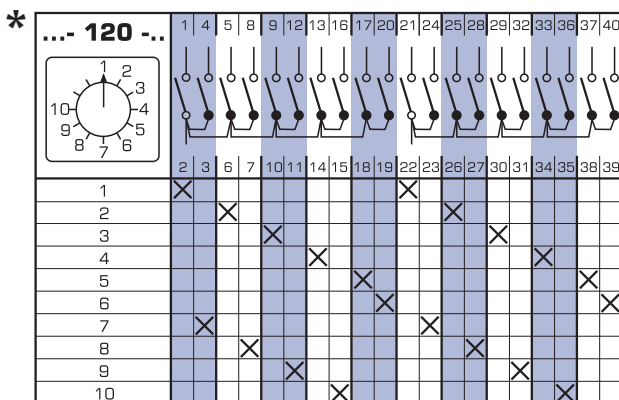
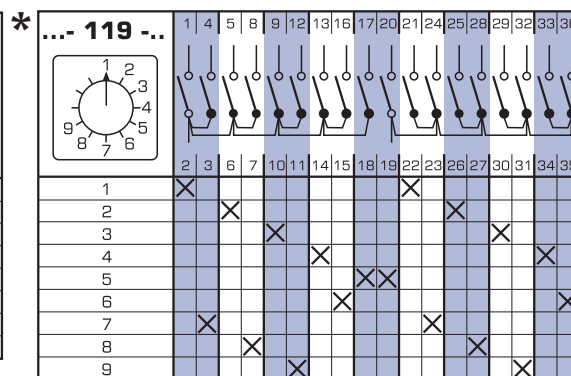
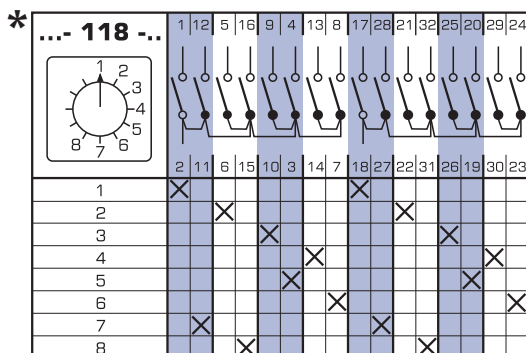
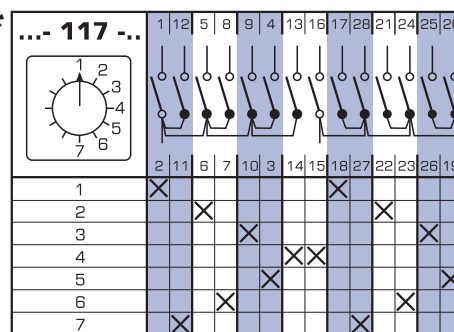
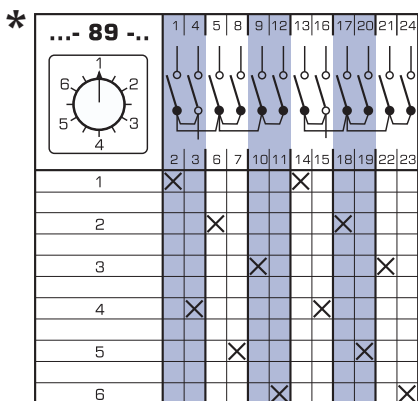
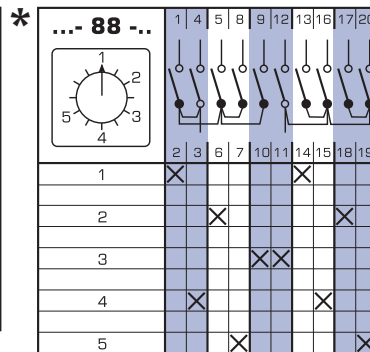
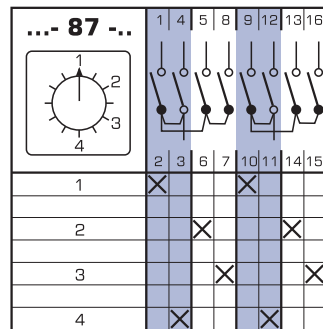
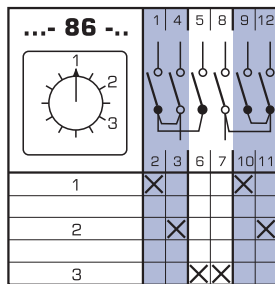

* Only in versions U, OU
 * See dimensions on pages 185-188

Multiposition switches without "0" position

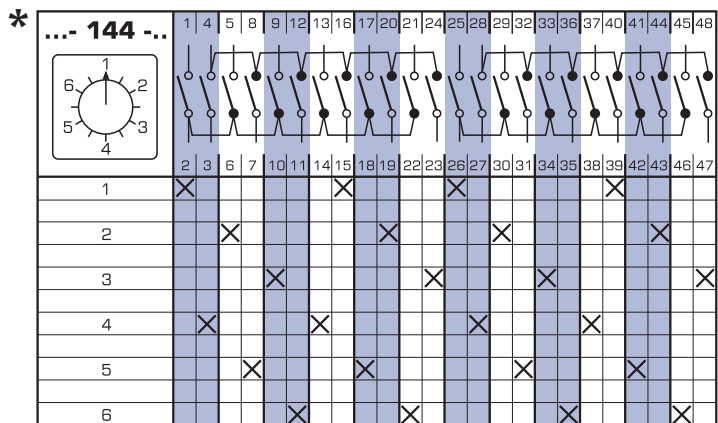
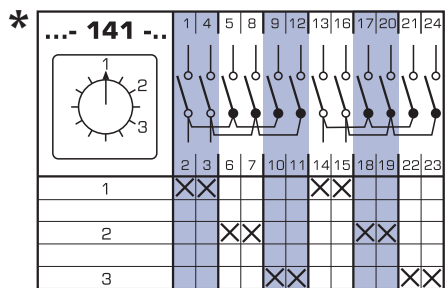
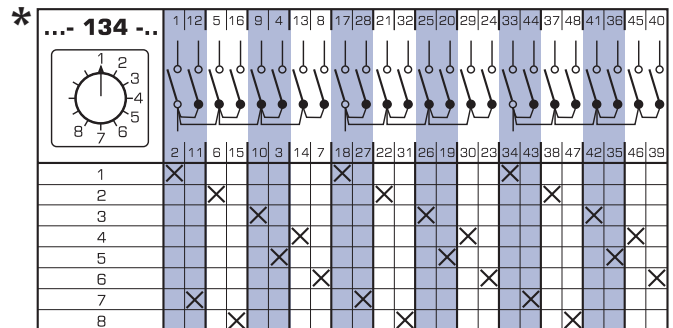
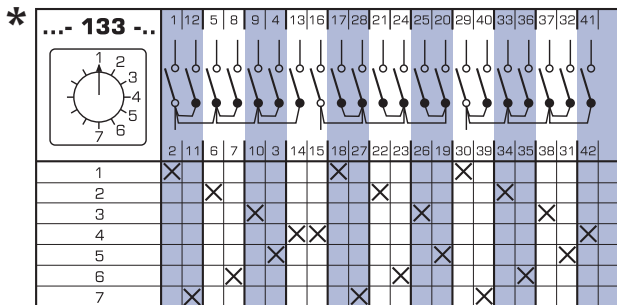
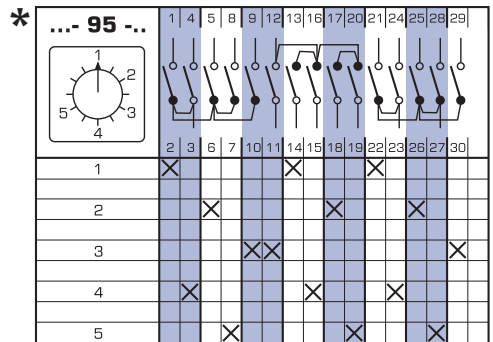
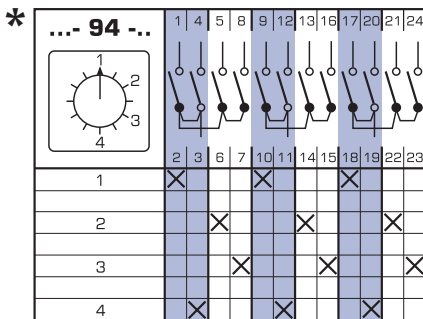
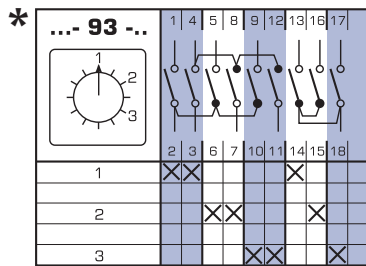
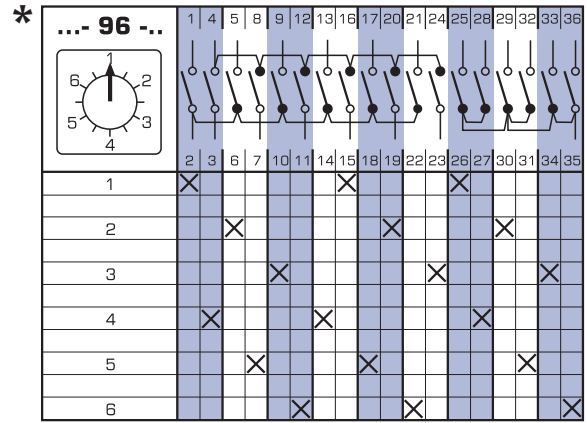
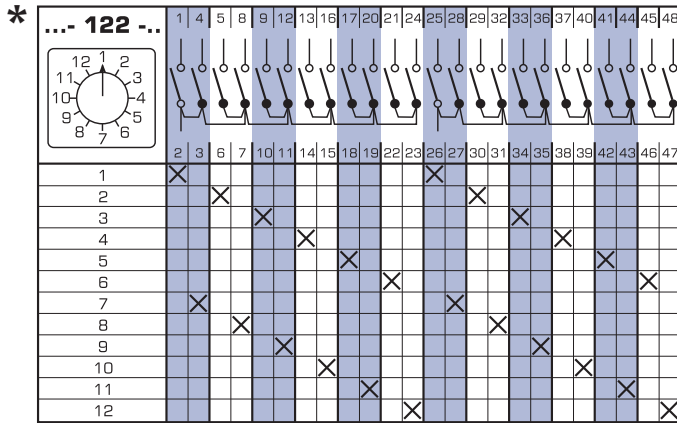

* Only in versions U, OU
* See dimensions on pages 185-188

Multiposition switches without "0" position

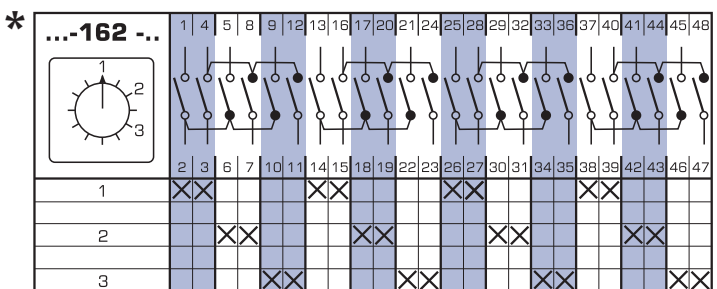
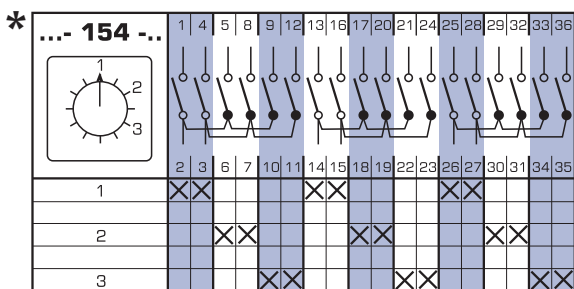
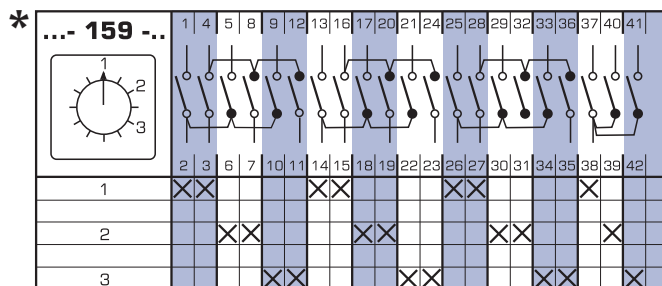
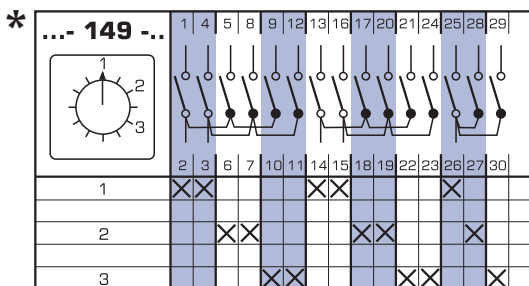
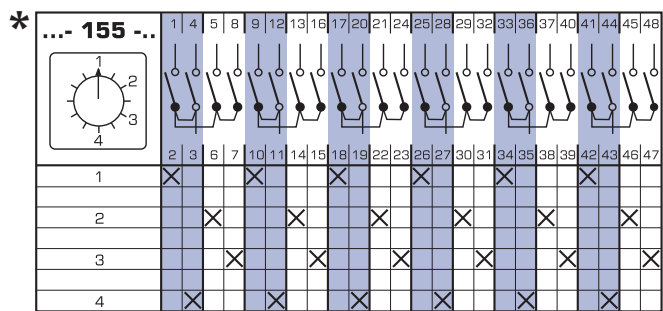
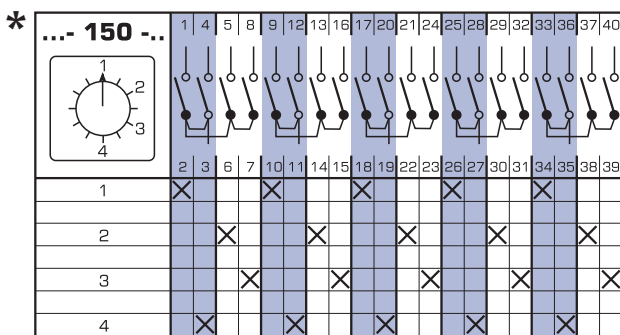
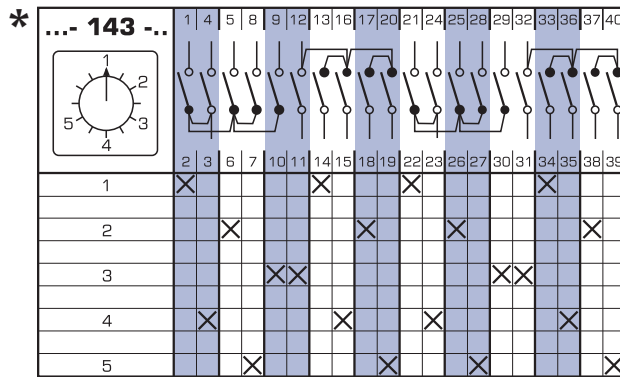
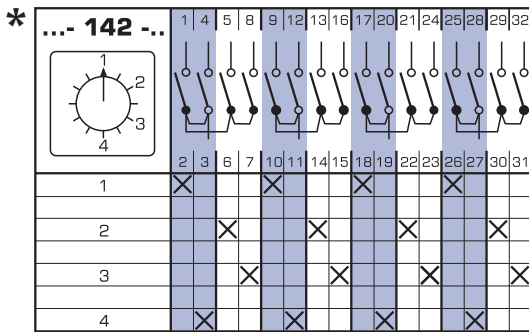

* Only in versions U, OU
 * See dimensions on pages 185-188

Switchgroups with "0" position

Table 139.

Switching program	Diagram number	
1-pole	2-group	251
	3-group	254
2-pole	2-group	252
	3-group	255
3-pole	2-group	253
	3-group	256

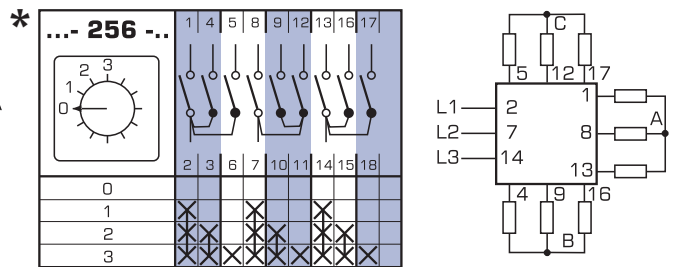
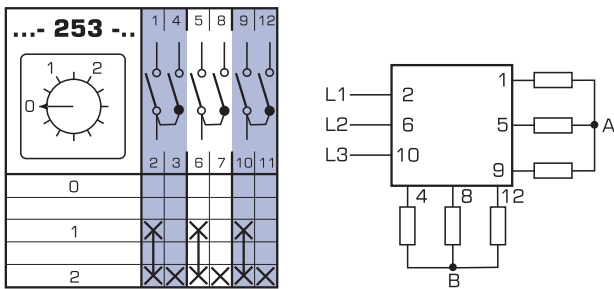
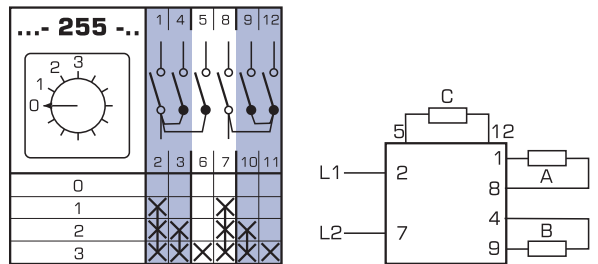
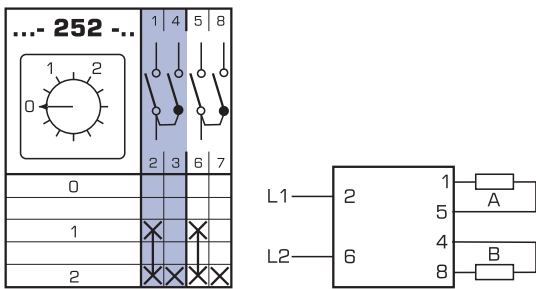
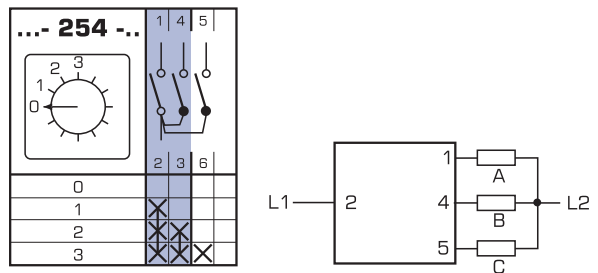
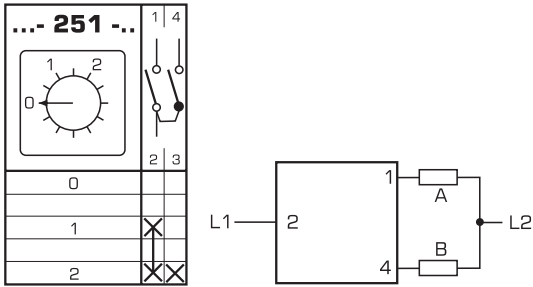

Serial switches

Table 140.

Switching program	Diagram number
1-pole	257
2-pole	258
3-pole	259

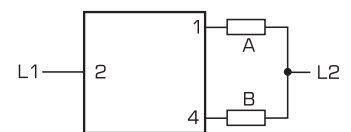
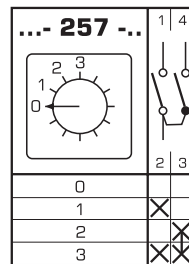

* Only in versions U, OU
* See dimensions on pages 185-188

Serial switches

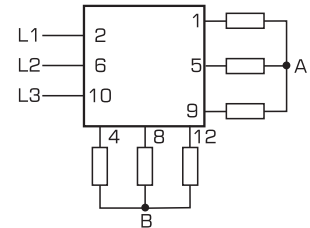
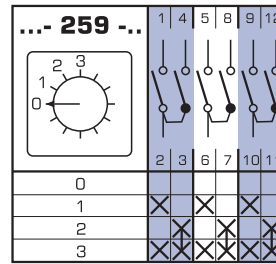
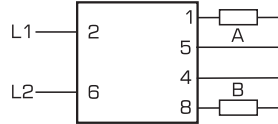
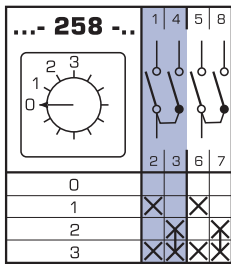

Serial-parallel switches

Table 141.

Switching program	Diagram number
2-pole	260

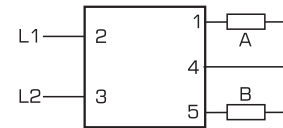
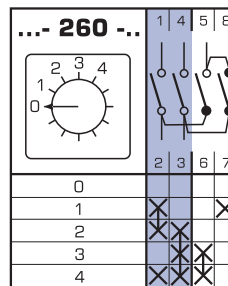

MEASUREMENT SWITCHES FOR VOLTAGE AND CURRENT

Ammeter switches

Table 142.

Switching program	Diagram number
phase measurement	L1-L2-L3 58
phase measurement	0-1-2-3 97
phase measurement with grounding	0-1-2-3 98

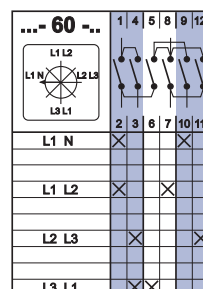
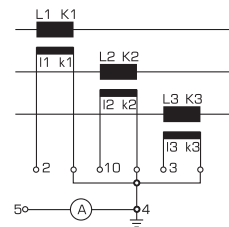
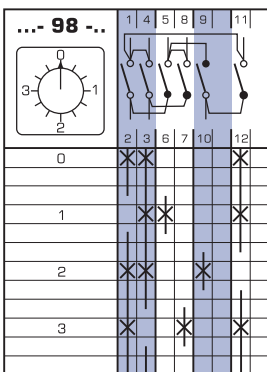
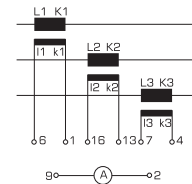
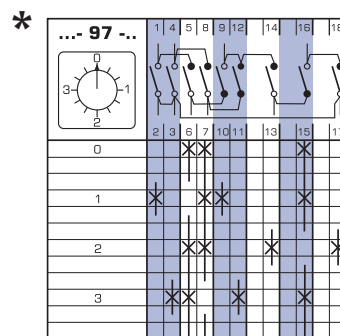
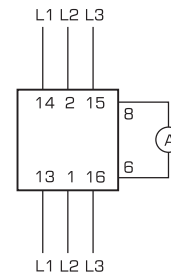
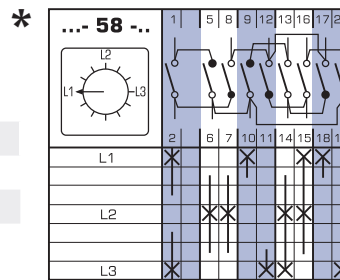

* Only in versions U, OU
* See dimensions on pages 185-188

MEASUREMENT SWITCHES FOR VOLTAGE AND CURRENT

Measurement switches for voltage and current, voltmeter switches without "0" position

Table 143.

Switching program	Diagram number
3 phase voltages	68
3 phase-to-phase voltages	67
3 phase-to-phase voltages+ phase voltage	66

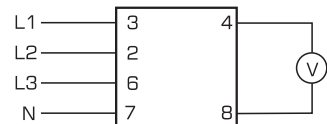
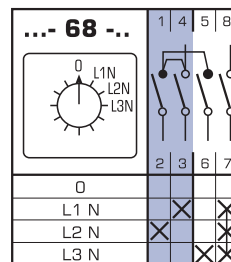
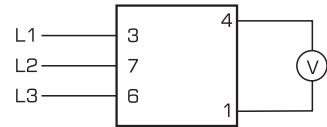
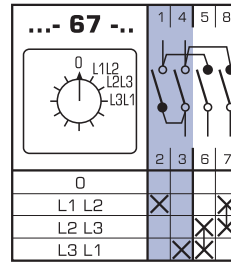
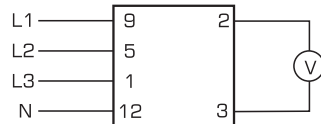
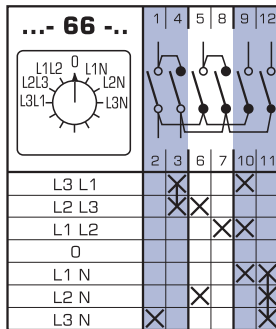

SWITCHES WITH SELF-RELING BACK TO THE OUTPUT POSITION

Switch with "0" position (1-0-2), return to "0" from both sides

Table 144.

Switching program	Diagram number
switches with automatic return to initial position, switch with function of left - right pushbuttons	210
switch with "0" position (1-0-2) return to "0" from both sides	
1-pole	201
2-pole	202
3-pole	203

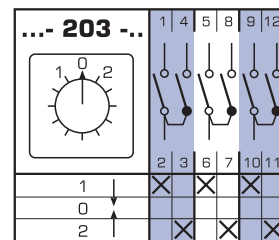
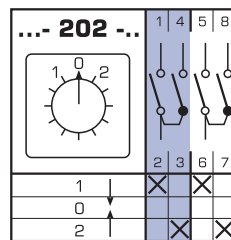
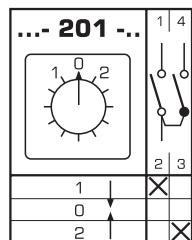
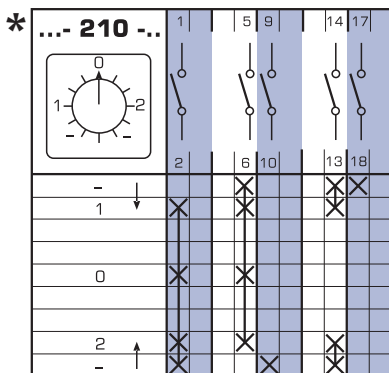

* Only in versions U, OU
* See dimensions on pages 185-188

SWITCHES WITH AUTOMATIC RETURN TO INITIAL POSITION

Switches without "0" (0-2) position

Table 145.

Switching program	Diagram number
1 normally closed contact + 1 normally open contact	204
2 normally closed contacts + 2 normally open contacts	205
3 normally closed contacts + 3 normally open contacts	206
to control a contactor – 1 normally open contact (turn right) and 1 normally closed contact (turn left)	207
1 normally open contact and 1 normally closed contact, when turning left and right	208
2 normally open contacts and 2 normally closed contacts, when turning left and right	209

SWITCH DISCONNECTORS FOR MOTOR CONTROLLING

Star-delta switch disconnectors

Table 146.

Switching program	Diagram number
basic version	12
Y/ Δ back from Y to 0	28
with counter-current braking back from Y to 0	29
as a voltage switch	30
for operation with contactor	31
bidirectional (left-right)	21

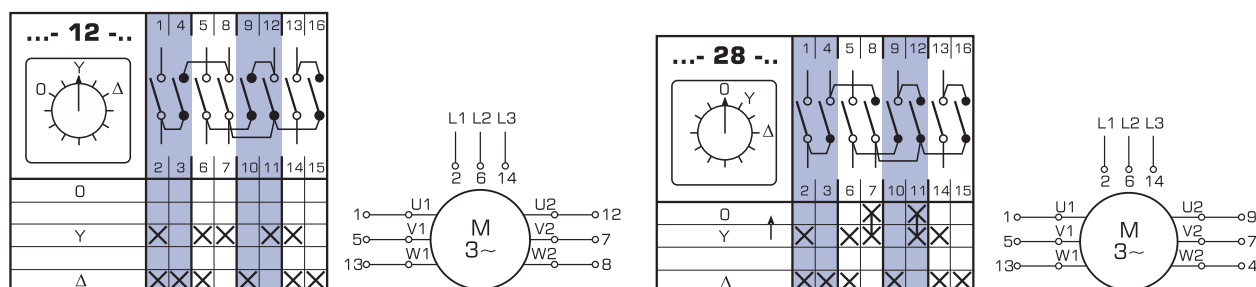

* See dimensions on pages 185-188

Star-delta switch disconnectors

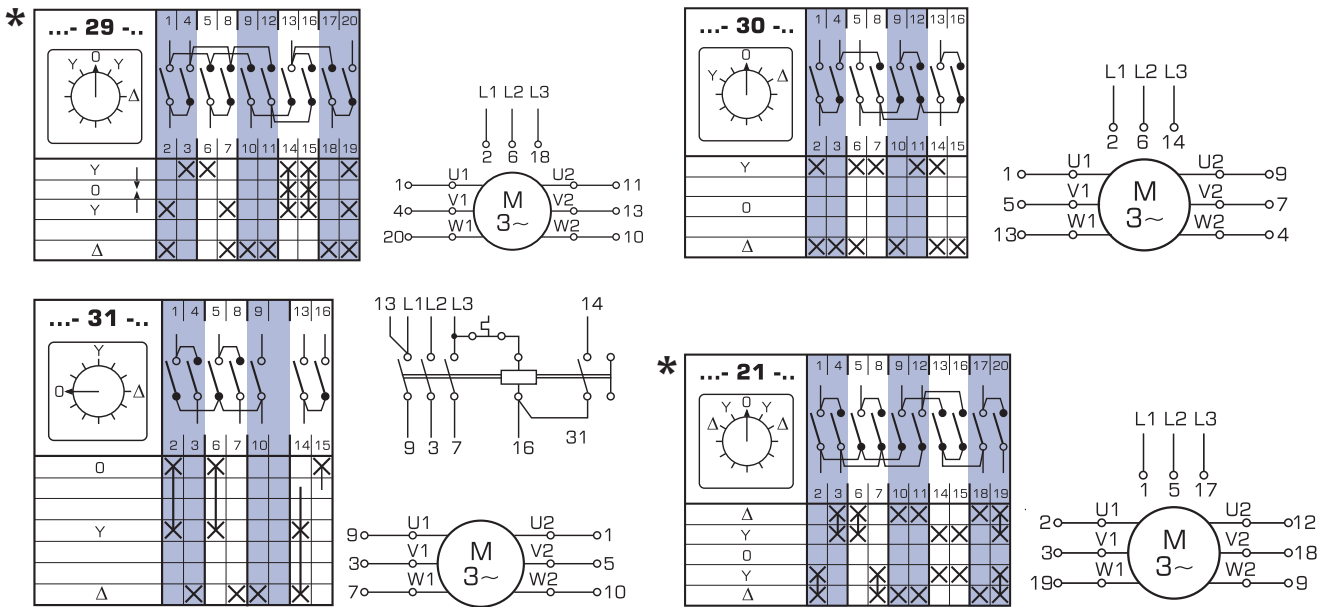

* Only in versions U, OU

Switch disconnectors in a Dahlander's system

Table 147.

Switching program	Diagram number
Switch disconnectors for motor controlling, switch disconnectors in a Dahlander's system dipolar Δ-0-YY	13
Dipolar 0-Δ-YY	19
Dipolar bidirectional YY-Δ-0-Δ-YY	20
Dipolar and contactor controlling	32

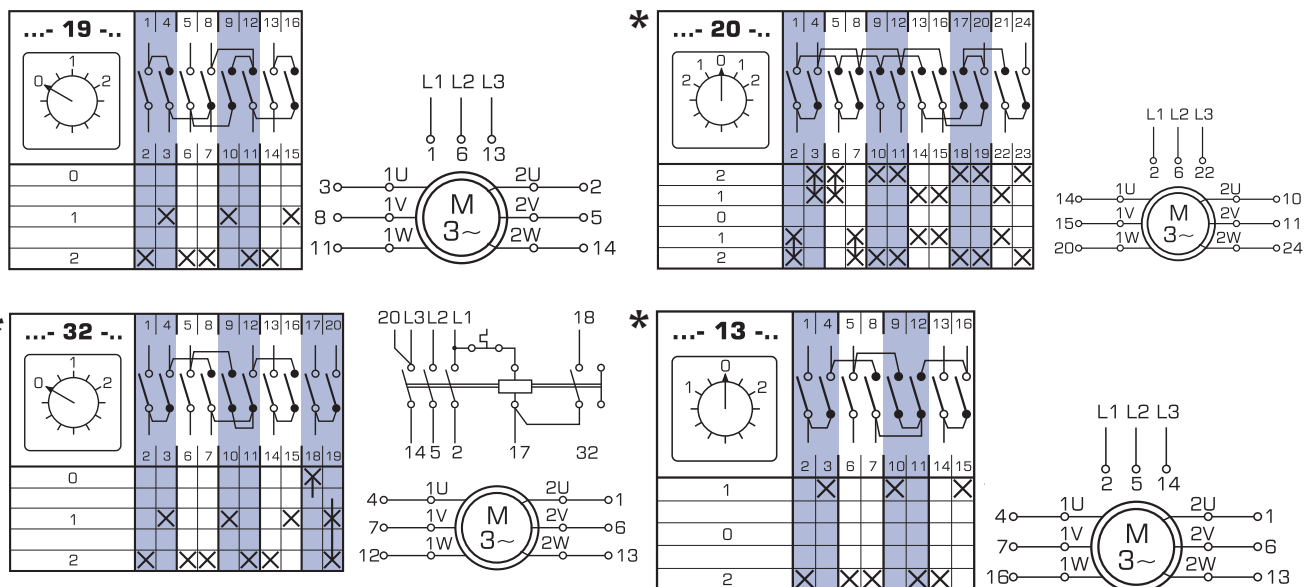

* Only in versions U, OU

* See dimensions on pages 185-188

SWITCH DISCONNECTORS FOR MOTOR CONTROLLING

Switch disconnectors for two-winding motors

Table 148.

Switching program	Diagram number
0-1-2	22
bidirectional to control the contactors	23
	33

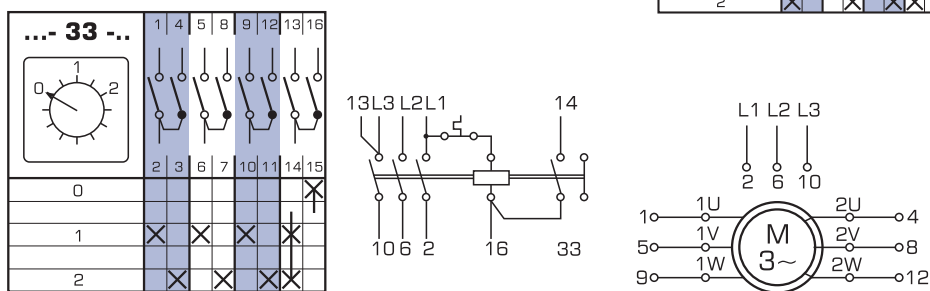
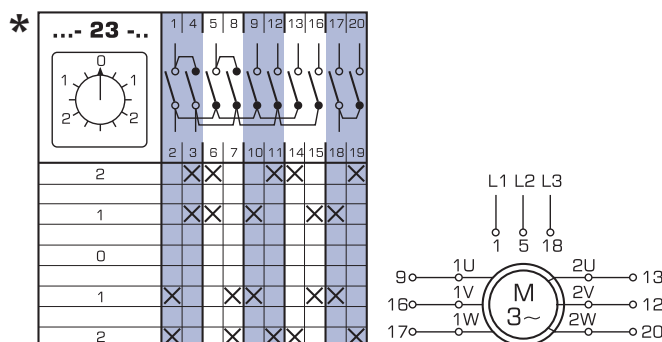
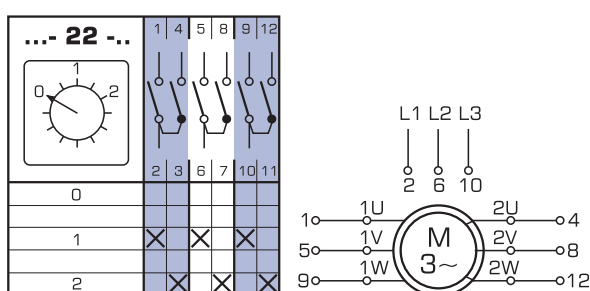

* Only in versions U, OU

* See dimensions on pages 185-188

Switch disconnectors for three-speed motors

Table 149.

Switching program	Diagram number
2 windings 0- Δ -Y-YY (with 3 speeds in a Dahlander's system)	34
2 windings 0- Δ -YY-Y (1 and 2 speeds in a Dahlander's system)	35
2 windings 0-Y- Δ -YY (2 and 3 speeds in a Dahlander's system)	36

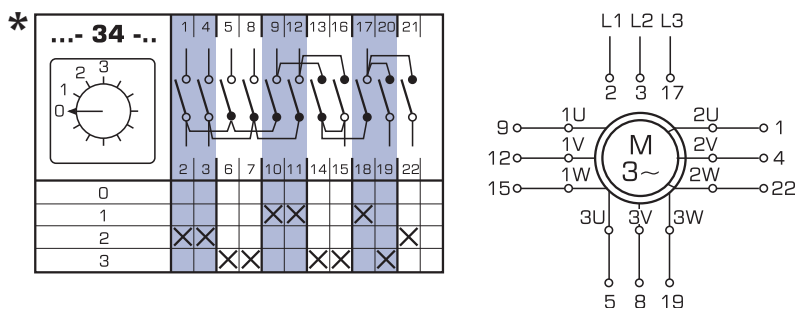

* Only in versions U, OU

* See dimensions on pages 185-188

Switch disconnectors for three-speed motors

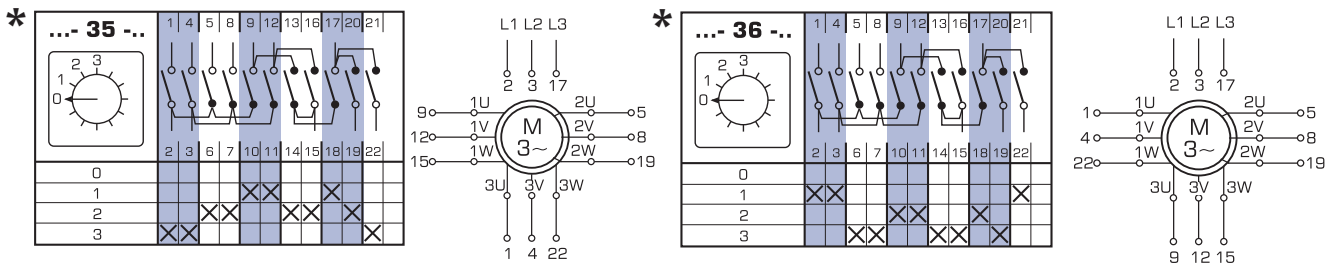

* Only in versions U, OU

SWITCH DISCONNECTORS FOR MOTOR CONTROLLING

Reversing switches

Table 150.

Switching program	Diagram number
2-pole	24
2-pole, return to "0" position	25
3-pole	11
3-pole, return to "0" position	26
to control a contactor	27
starting switches for 1-phase motors	15

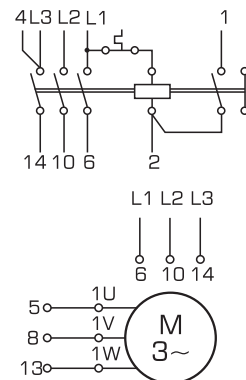
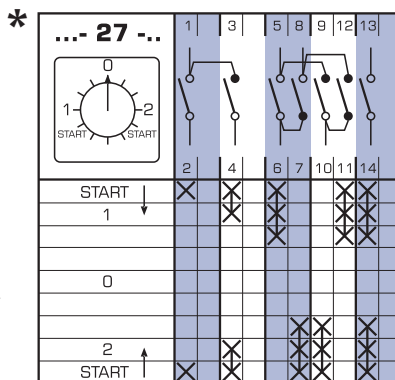
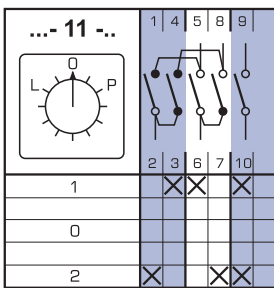
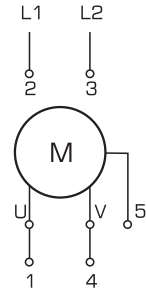
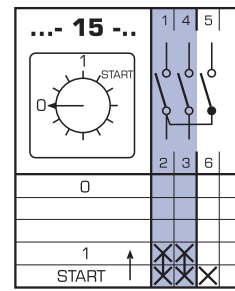
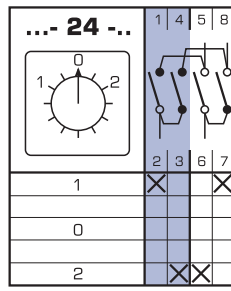
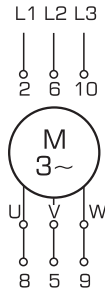
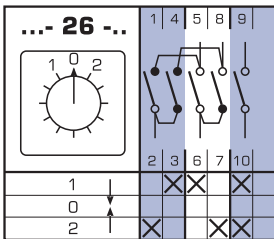
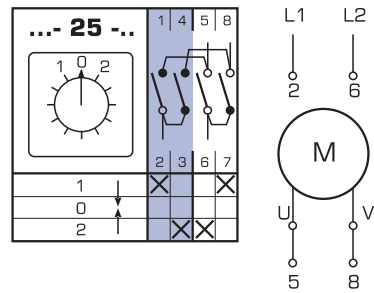

* Only in versions U, OU

* See dimensions on pages 185-188

OVERALL DIMENSIONS

Standard version front plate

Group	B ∅	E
A0	48	7,5
A1	65	9,5
A2	90	9,5
A3	132	10

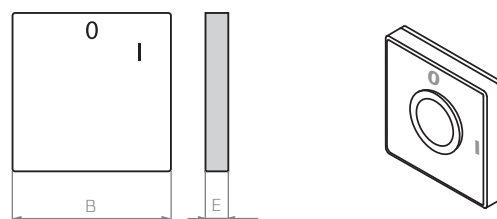

Group	D	P	R	B	F
	∅				
A0	27,5	19	23,5	39,5	16
A1	35	25	32	53	20
A2	48	32	43,5	70,5	26
A3	75	46,5	63,5	104	39

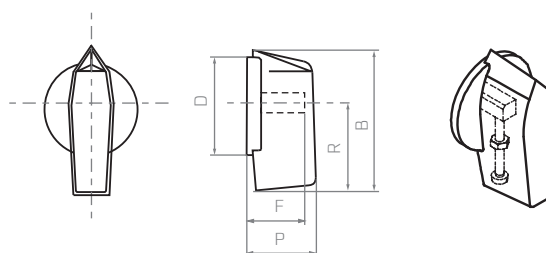

Group	D	P	R	B	F
	∅				
A1	35	51	61,5	81,5	15
A2	48	64	79,5	105,5	19
A3	75	88	115	155,5	28

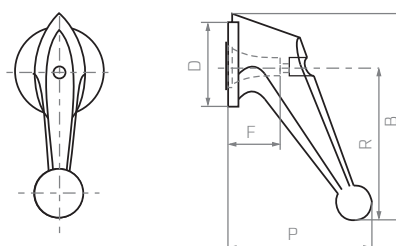

Switches installed under the panel

Group	D1	D2	A
	∅	∅	∅
A0	5	14	36
A1	5	14	48
A2	6	16	72
A3	6	18	104

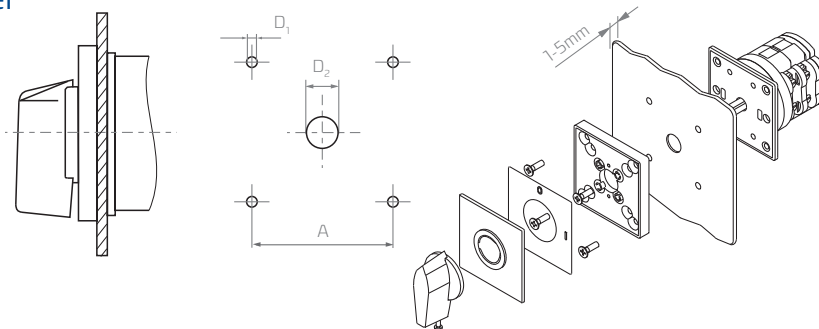

Switches installed on the panel

Group	D1	D2	A
	∅	∅	∅
A0	5	42,5	36
A1	5	59	48
A2	6	82	72

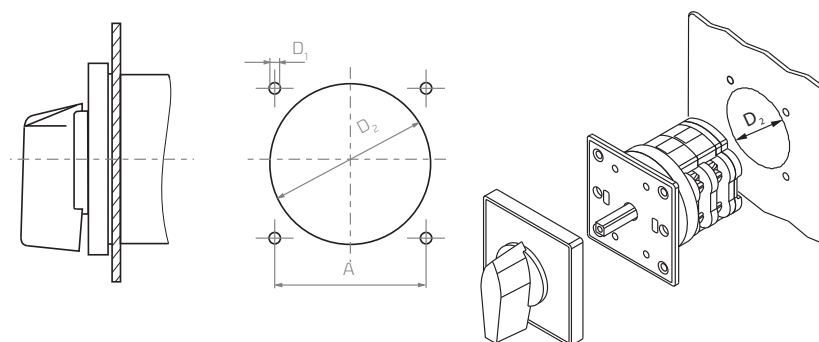

OVERALL DIMENSIONS

U switches to be built-in

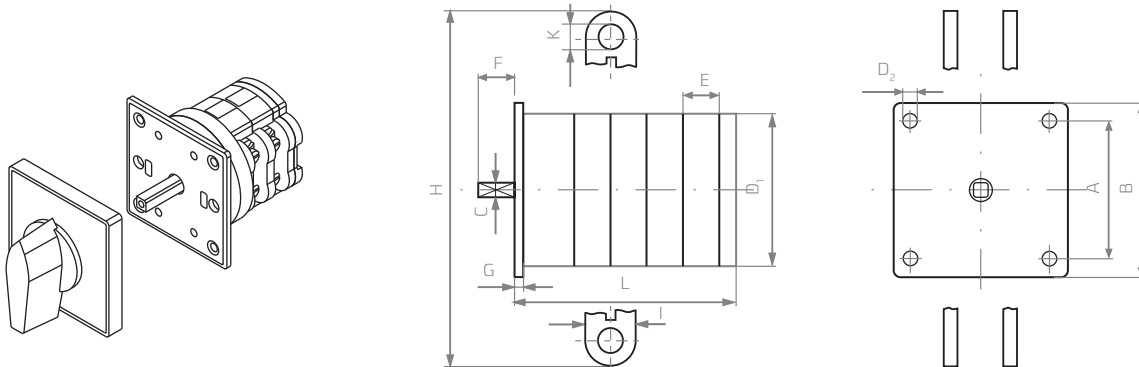

Group	Switch type	D ₁	D ₂	A	B	C	E	F	G	H	I	K
		∅	∅	∅	∅	∅						
A0	4G 10	38	4,3	36	48	6	9,6	22	4	–	–	–
A1	4G 16	57	4,3	48	65	6	13,5	26	3	–	–	–
	4G 25	57	4,3	48	65	6	13,5	26	3	–	–	–
A2	4G 40	80	5,3	72	90	8	18	31	5	–	–	–
	4G 63, 80	80	5,3	72	90	8	18	31	5	–	–	–
A3	4G 100	120	5,3	104	132	10	29	37,5	6	–	–	–
	4G 200	120	5,3	104	132	10	29	37,5	6	145	20	10,5
	4G 400	120	5,3	104	132	10	29	37,5	6	170	45	13
	4G 630	120	5,3	104	132	10	29	37,5	6	190	74	17,5
	4G 800	120	5,3	104	132	10	29	37,5	6	260	50	17,5
	4G 1200	120	5,3	104	132	10	29	37,5	6	260	80	17,5

Group	Switch type	L (depending on the number of switching elements)											
		1	2	3	4	5	6	7	8	9	10	11	12
A0	4G 10	33	42,5	52	61,5	71	81	90,5	100	109,5	119	129	138,5
A1	4G 16	46,5	60	73,5	87,5	101	114,5	128,5	143	156	169,5	183	196,5
	4G 25	46,5	60	73,5	87,5	101	114,5	128,5	143	156	169,5	183	196,5
A2	4G 40	56,5	74,5	92,5	110,5	128,5	146,5	164,5	182,5	200,5	218,5	236,5	254,5
	4G 63, 80	56,5	74,5	92,5	110,5	128,5	146,5	164,5	182,5	200,5	218,5	236,5	254,5
A3	4G 100	77	107	136	166	196	226	284	314	343	373	402	432
	4G 200	77	107	136	166	196	226	284	314	343	373	402	432
	4G 400	–	107	–	166	–	226	–	314	–	373	–	432
	4G 630	–	–	136	–	–	226	–	–	343	–	–	432
	4G 800	–	107	–	166	–	226	–	314	–	373	–	432
	4G 1200	–	–	136	–	–	226	–	–	343	–	–	432

protection degree IP40 (from the front plate side), IP55 in a special version – S1

OVERALL DIMENSIONS

OU switches to be built in a housing

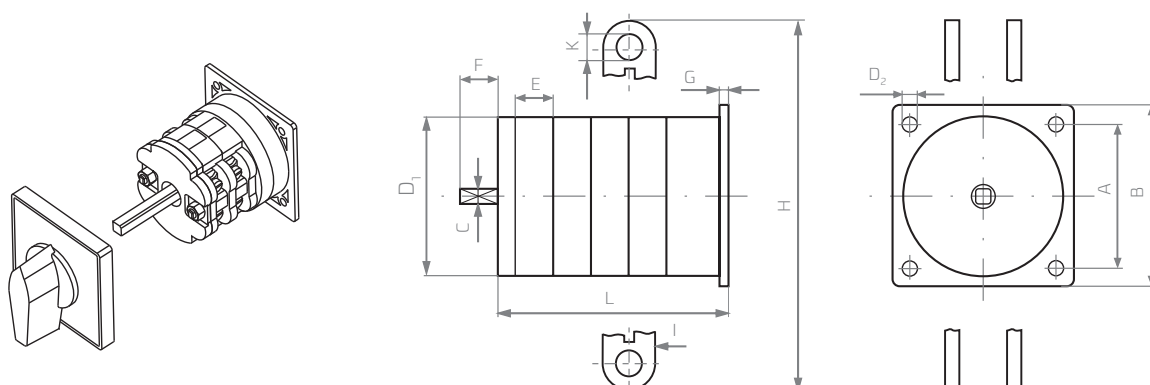

Group	Switch type	D ₁	D ₂	A	B	C	E	F	G	H	I	K
		∅	∅	∅	∅	∅						
A0	4G 10	38	4,3	36	48	6	9,6	32	4	–	–	–
A1	4G 16	57	4,3	48	65	6	13,5	35	3	–	–	–
	4G 25	57	4,3	48	65	6	13,5	35	3	–	–	–
A2	4G 40	80	5,3	72	90	8	18	40	5	–	–	–
	4G 63,80	80	5,3	72	90	8	18	40	5	–	–	–
A3	4G 100	120	5,3	104	132	10	29	50	6	–	–	–
	4G 200	120	5,3	104	132	10	29	50	6	145	20	10,5
	4G 400	120	5,3	104	132	10	29	50	6	170	45	13
	4G 630	120	5,3	104	132	10	29	50	6	190	74	17,5
	4G 800	120	5,3	104	132	10	29	50	6	260	50	17,5
	4G 1200	120	5,3	104	132	10	29	50	6	260	80	17,5

Group	Switch type	L (depending on the number of switching elements)											
		1	2	3	4	5	6	7	8	9	10	11	12
A0	4G 10	33	46,5	56	65,5	75	85	94,5	104	113,5	123	133	142,5
A1	4G 16	46,5	60	73,5	87,5	101	114,5	128,5	143	156	169,5	183	196,5
	4G 25	46,5	60	73,5	87,5	101	114,5	128,5	143	156	169,5	183	196,5
A2	4G 40	56,5	74,5	92,5	110,5	128,5	146,5	164,5	182,5	200,5	218,5	236,5	254,5
	4G 63,80	56,5	74,5	92,5	110,5	128,5	146,5	164,5	182,5	200,5	218,5	236,5	254,5
A3	4G 100	77	107	136	166	196	226	284	314	343	373	402	432
	4G 200	77	107	136	166	196	226	284	314	343	373	402	432
	4G 400	–	107	–	166	–	226	–	314	–	373	–	432
	4G 630	–	–	136	–	–	226	–	–	343	–	–	432
	4G 800	–	107	–	166	–	226	–	314	–	373	–	432
	4G 1200	–	–	136	–	–	226	–	–	343	–	–	432

protection degree IP40 (from the front plate side), IP55 in a special version – S1

INSTALLATION DIMENSIONS

PK switches in a plastic housing - protection degree IP 55

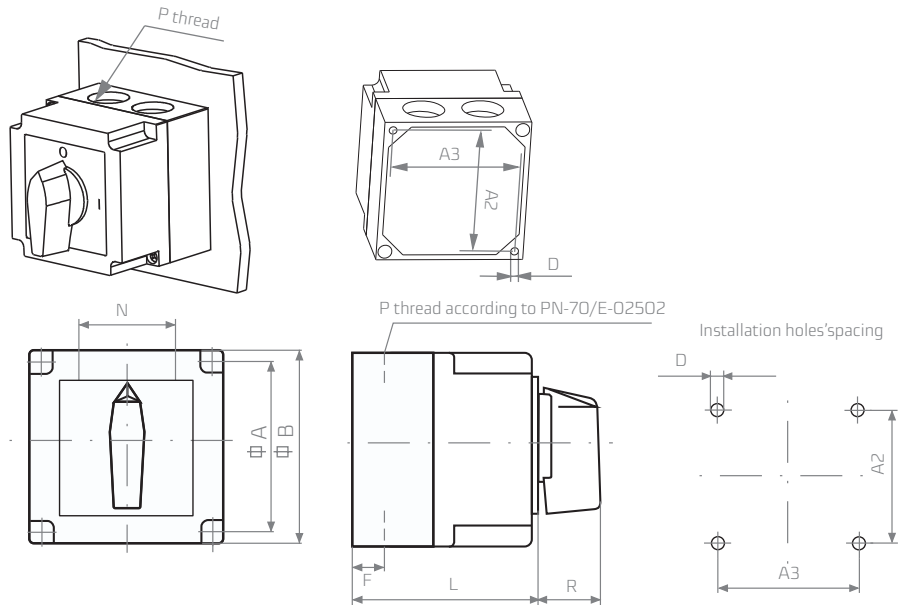

Group	Switch type	D	A	A2	A3	B	F	N	R	Thread		L (depending on the number of the switching elements)			
		∅	∅			∅				P	M	1	2	3	4
A0	4G 10	4,3	55	38	54	64	13	25	19	11	-	55,5	55,5	75	75
A1	4G 16	4,3	75	75	75	85	19	34	25	16	20	77	77	104	104
	4G 25	4,3	75	75	75	85	19	34	25	16*	20	77	77	104	104
A2	4G 40	5,3	109	91	107	120	29	45	32	21*	-	95	95	132	132
	4G 63, 4G 80	5,3	109	91	107	120	29	45	32	21	-	95	95	132	132

* to order

PK cam switches in thermoplastic enclosures with IP 65 degree of protection

Installation holes' spacing

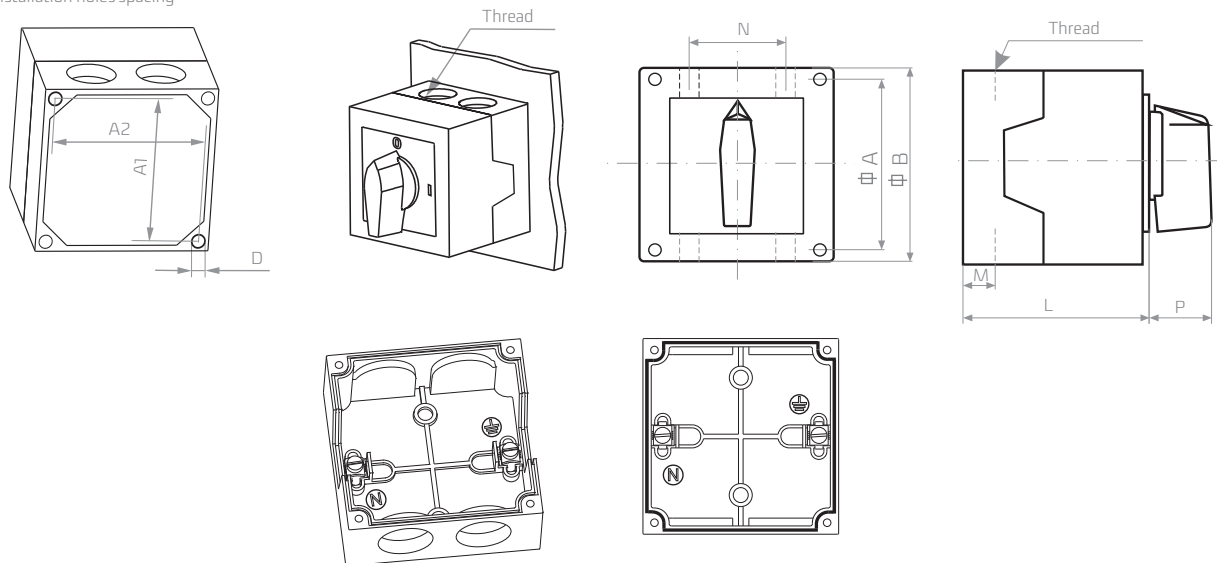

Group	Switch type	D	A	B	A1	A2	M	N	P	Thread	L (depending on the number of the switching elements)	
		∅	∅	∅							1 or 2	3 or 4
A0	4G 10	4,5	64	75	50	64	14	28	19	M20	60	81,5

SPECIAL VERSIONS

S1 switch with a sealed shaft /protection class IP 55/

Group A0, A1, A2 version U, OU

The difference between standard and special versions is the use of a sealing ring on the driving shaft, which guarantees achieving an IP 55 housing tightness.

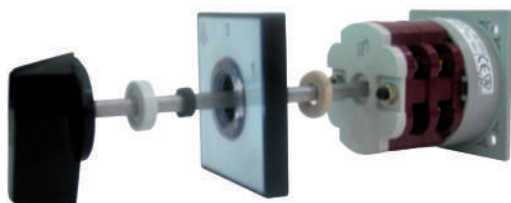

S5 switch with a cylindrical lock

Group A1, A2 version U

Blocking when ordered.

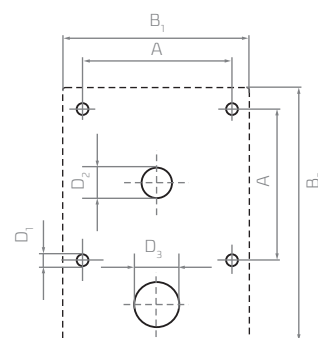
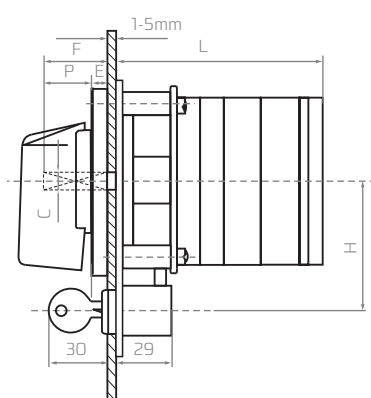

Group	D ₁	D ₂	D ₃	A	B ₁	B ₂	C	E	F	H	P	
								Φ				
A1	5	14	21,5	48	65	98	6	9,5	26	48	25	
A2	6	16	21,5	72	90	122	8	9,5	31	60	32	

Group	L (depending on the number of the switching elements)											
	1	2	3	4	5	6	7	8	9	10	11	12
A1	72,5	86	99,5	113,5	127	140,5	154,5	169	182	195,5	209	222,5
A2	82,5	100,5	118,5	136,5	154,5	172,5	190,5	208,5	226,5	244,5	262,5	280,5

S6 Switch with padlock blocking

Group A0, A1, A2 version U, OU, PK
Blocking only in 0 position

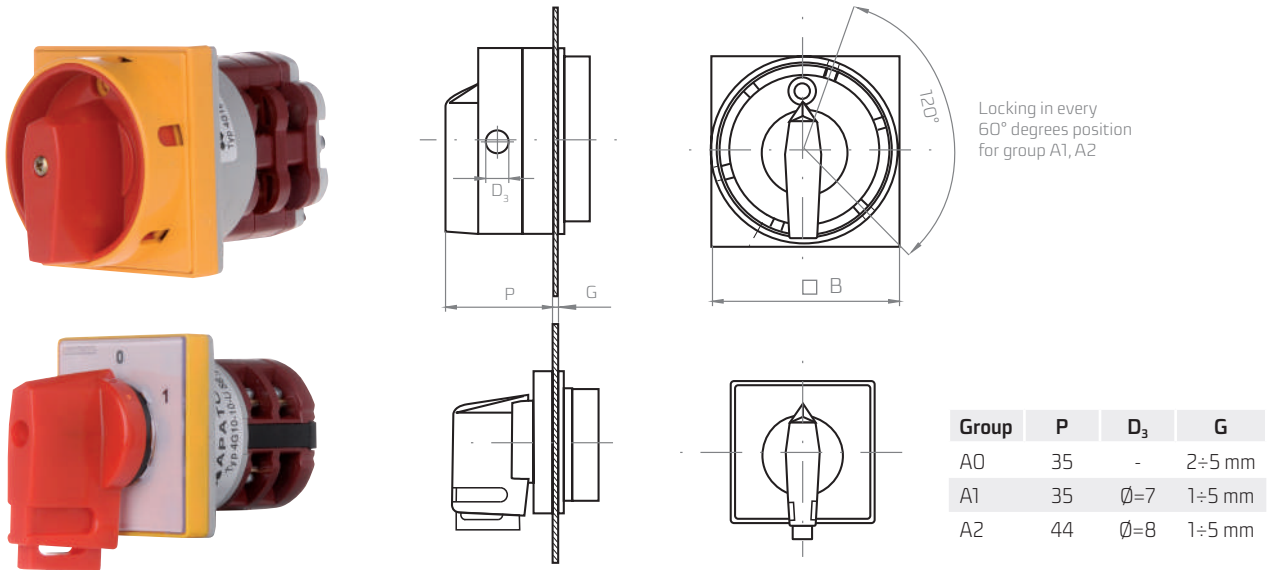

S7 Switch with a door coupling

Group A1, A2 version OU

The switch for installation on the back wall of the housing /cubicle/. The knob with a front plate is placed on the cover or on the door.
The shaft may be lengthened and sealed.

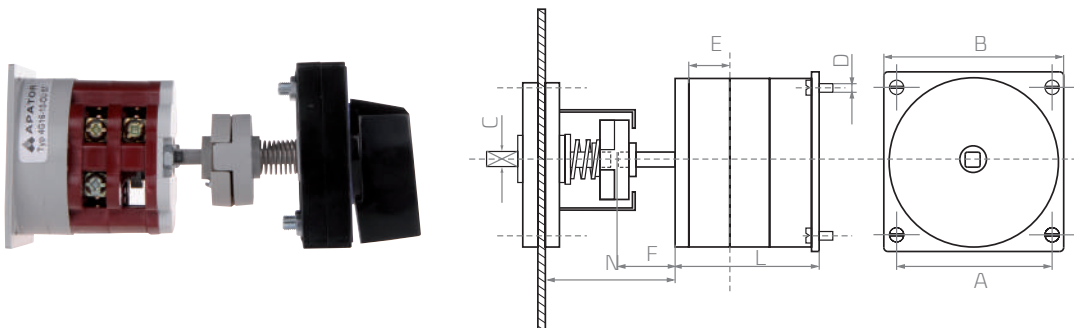

S8 Switch with a door coupling and a door blocking

Group A1, A2 version OU

The features are like for S7, but the door can be opened in a 0 position, for example.

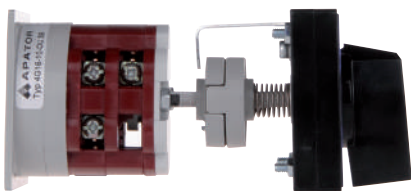

Group	D	A	B	C	E	F	N	L (depending on the number of the switching elements)											
	∅	∅	∅	∅				1	2	3	4	5	6	7	8	9	10	11	12
A1	4	48	65	6	13,5	16,5	54	46,5	60	73,5	87,5	101	114,5	128,5	143	156	169,5	183	196,5
A2	5	72	90	8	18	17	60	56,5	74,5	95,5	110,5	128,5	146,5	164,5	182,5	200,5	218,5	236,5	254,5

S9 Switch for installation in $\varnothing 30,5$ (in control boards with standard holes)

Group AO version U

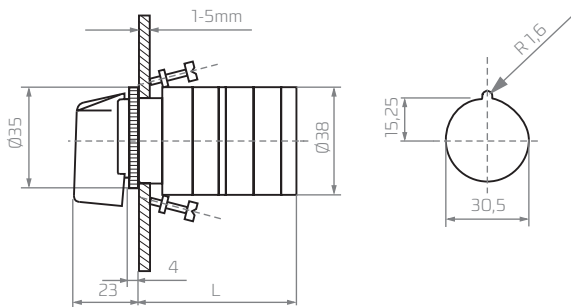

S10 Switch for installation in a $\varnothing 30,5$ hole

Group AO version U

(Like for S9), the key operates as a knob. Closing in positions 3, 6, 9, 12 /like on a clock/. The key can be removed in the same positions.

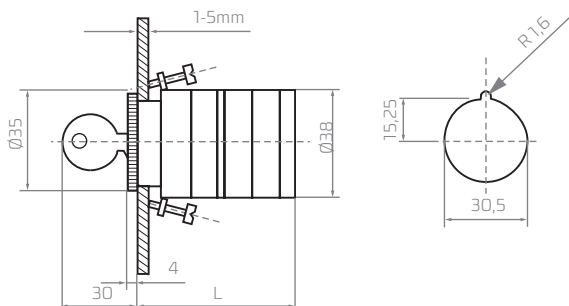

S11 Switch for installation in a $\varnothing 22,5$ hole (control boards)

Group AO version U

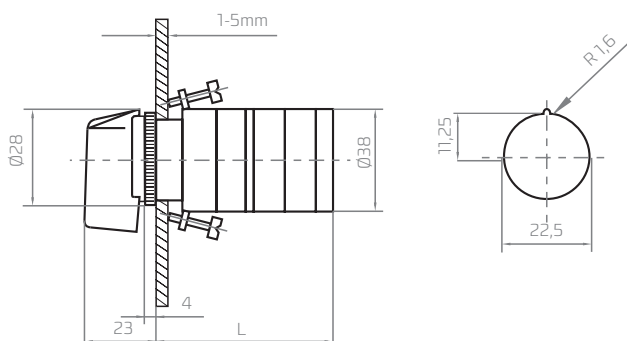

S12 switch for installation in a $\varnothing 22,5$ hole (like for S11)

Group A0 version U

The key operates as a knob. Closing and removing the key in positions like for S10.

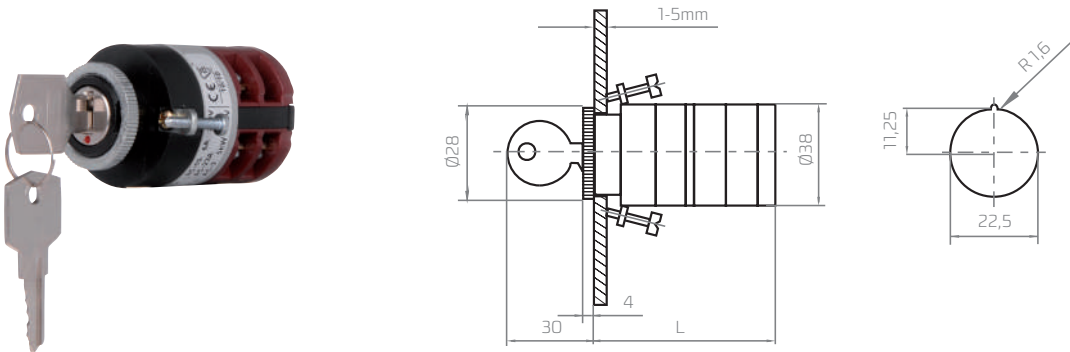

Version: S9, S10, S11, S12	L (dependent on the number of switching elements)											
	1	2	3	4	5	6	7	8	9	10	11	12
	47	56,5	66	75,5	85	95	104,5	114	123,5	133	143	152,5

S15 Switch with a signal lamp

Group A0, A1, A2 version U, OU, PK*)

*protection degree IP52

(Standard colour – red; 220 V).

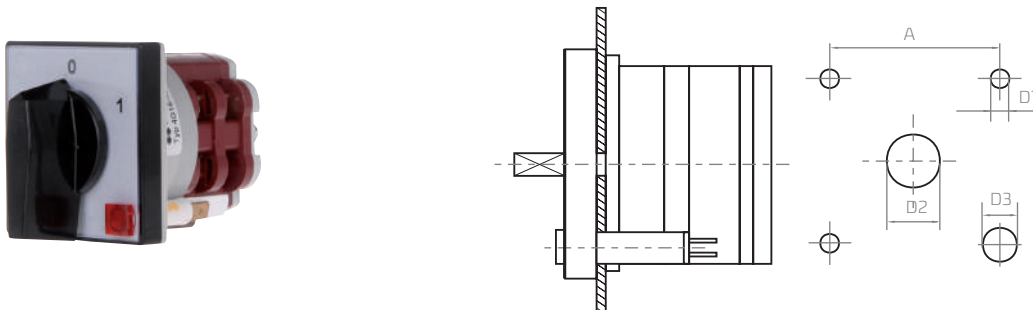

Group	A	D ₁	D ₂	D ₃
	Φ	\varnothing	\varnothing	\varnothing
A0	35	5	14	9
A1	48	5	14	9
A2	72	6	16	9

S18 Switch for installation on din rail (according to 35 DIN EN 50022)

Group A0, A1, A2 version U

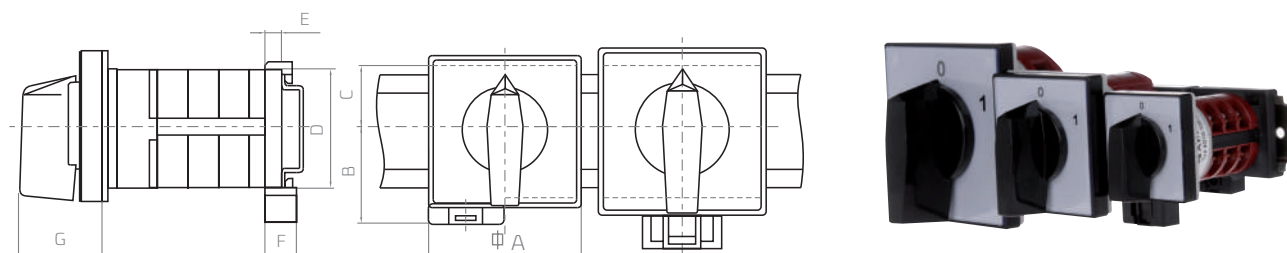

Group	A	B	C	D	E	F	G
	Φ						
A0	48	30	21	35	5	10,5	26,5
A1	65	48,5	21	35	9	15	34,5
A2	90	48,5	21	35	9	15	41,5

S19 Switch with a protective housing (up to two packs)

Group A1, A2 version U, OU

Protection to prevent from touching the terminals.

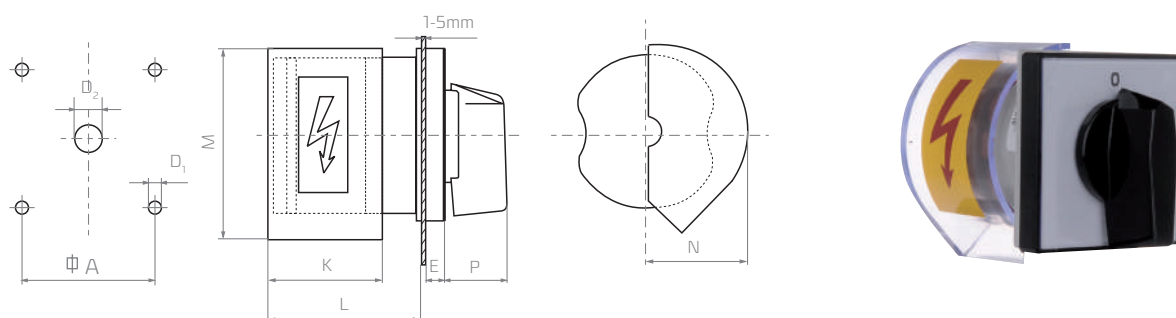

Group	D ₁	D ₂	A	E	P	K	M	N	L
	\emptyset	\emptyset	Φ						
A1	5	14	48	9,5	25	51	78	36	69
A2	6	16	72	9,5	32	58	99	53	78

S21 Main switch disconnector according to IEC 204 and VDE 0113

Group A1, A2, A3 version U

Black knob, front plate and indicating plate, white markings. Protecting housing like in S19. Blocking lock. Blocking according to order.

S22 Emergency and main switch disconnector (for two packs)

Group A1, A2, A3 version U

Red knob, yellow background of an indicating plate, black markings. Protecting housing like in S19. Blocking lock. Blocking according to order.

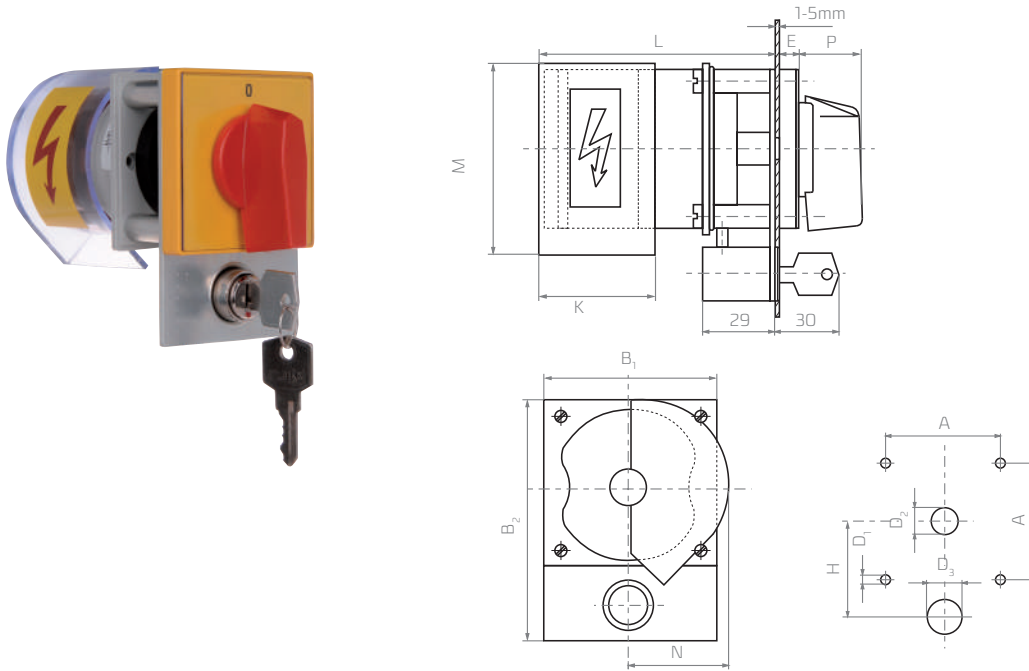

Group	D ₁	D ₂	D ₃	A	B ₁	B ₂	P	K	M	N	L	E	H
	∅	∅	∅										
A1	5	14	21,5	48	65	98	25	51	78	36	95	9,5	48
A2	6	16	21,5	72	90	122	32	58	99	53	104	9,5	60
A3	6	18	21,5	104	132	168	46,5	88	132	78	137	10	85

S24 Emergency switch disconnector according to IEC 204 and VDE 0113

Group A0, A1, A2 version U, OU, PK

Red knob, yellow background of an indicating plate, black markings.

The difference between standard and special versions is in different colours of a knob and a plate (red knob, yellow plate, black signs).



S25 Main and emergency switch disconnector (for two packs)

Group A1, A2 version U, OU

The blocking position should be specified (red knob, yellow front plate) in the order. Blocking only in 0 position.

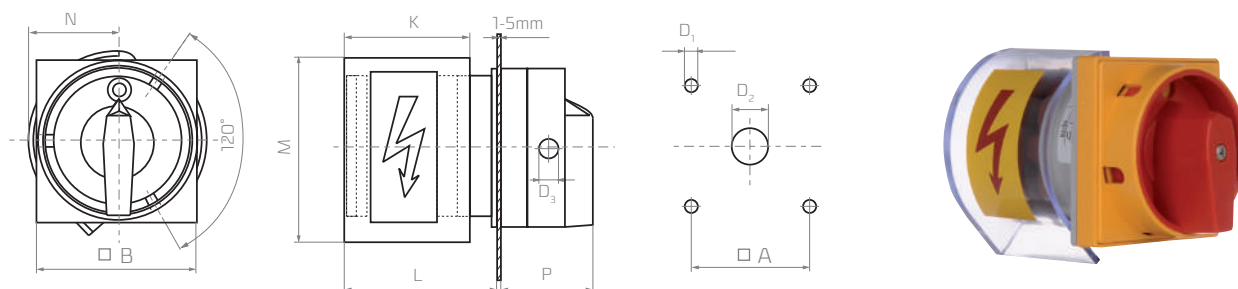

Group	D ₁	D ₂	D ₃	A	B	P	K	M	N	L
	∅	∅	∅	∅	∅					
A1	5	14	7	48	65	35	51	78	36	69
A2	6	16	8	72	90	44	58	99	53	78

S29 Switch for installation in a ∅22,5 hole /in control boards/

Group A0 version U

The key operates as a knob. Closing in positions 3, 6, 9, 12 /like on a clock/. The key can be removed in the same positions. It is possible to remove the key in the same positions.

S30 Switch for installation in a ∅30,5 hole with a front plate /in control boards/

Group A0 version U

The key operates as a knob. Closing in positions 3, 6, 9, 12 /like on a clock/. The key can be removed in the same positions. It is also possible to remove the key in any position.

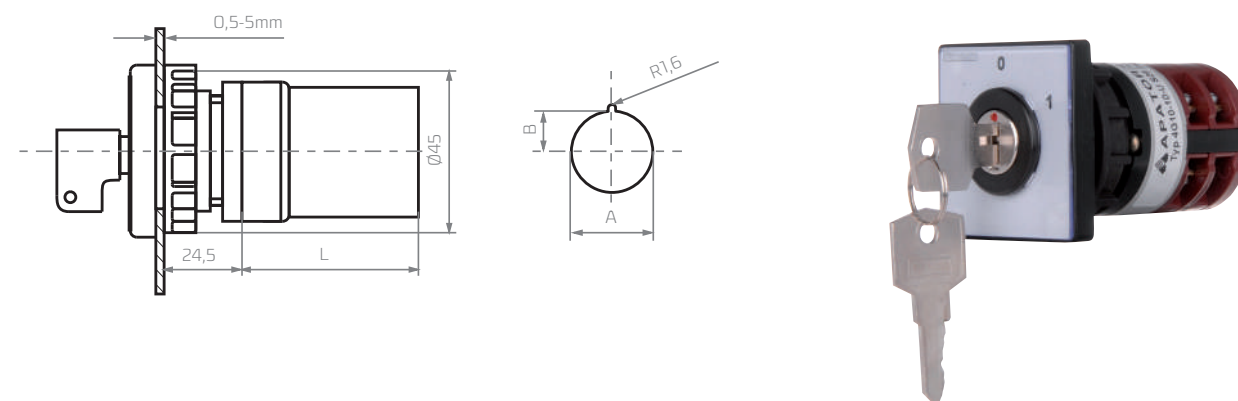

Group	S29	S30
A	22,5	30,5
B	11,25	15,25

The number of the switching elements	1	2	3	4	5	6	7	8	8	10	11	12
L	29	38,5	48	57,5	67	77	86,5	96	105,5	115	125	134

THE CHOICE OF THE MOTOR SWITCHES

Contact life depends on loading conditions. In AC-1 utilization category, where making currents and breaking currents are the same and equal the rated current, the contact life of the switches up to 4G 63 size reaches one million of switching operations.

In more difficult operating conditions the contact life becomes lower. The diagram presented below can be used to make an approximate choice of motor switches, depending on voltage, motor power, number of switching operations per hour and usage class.

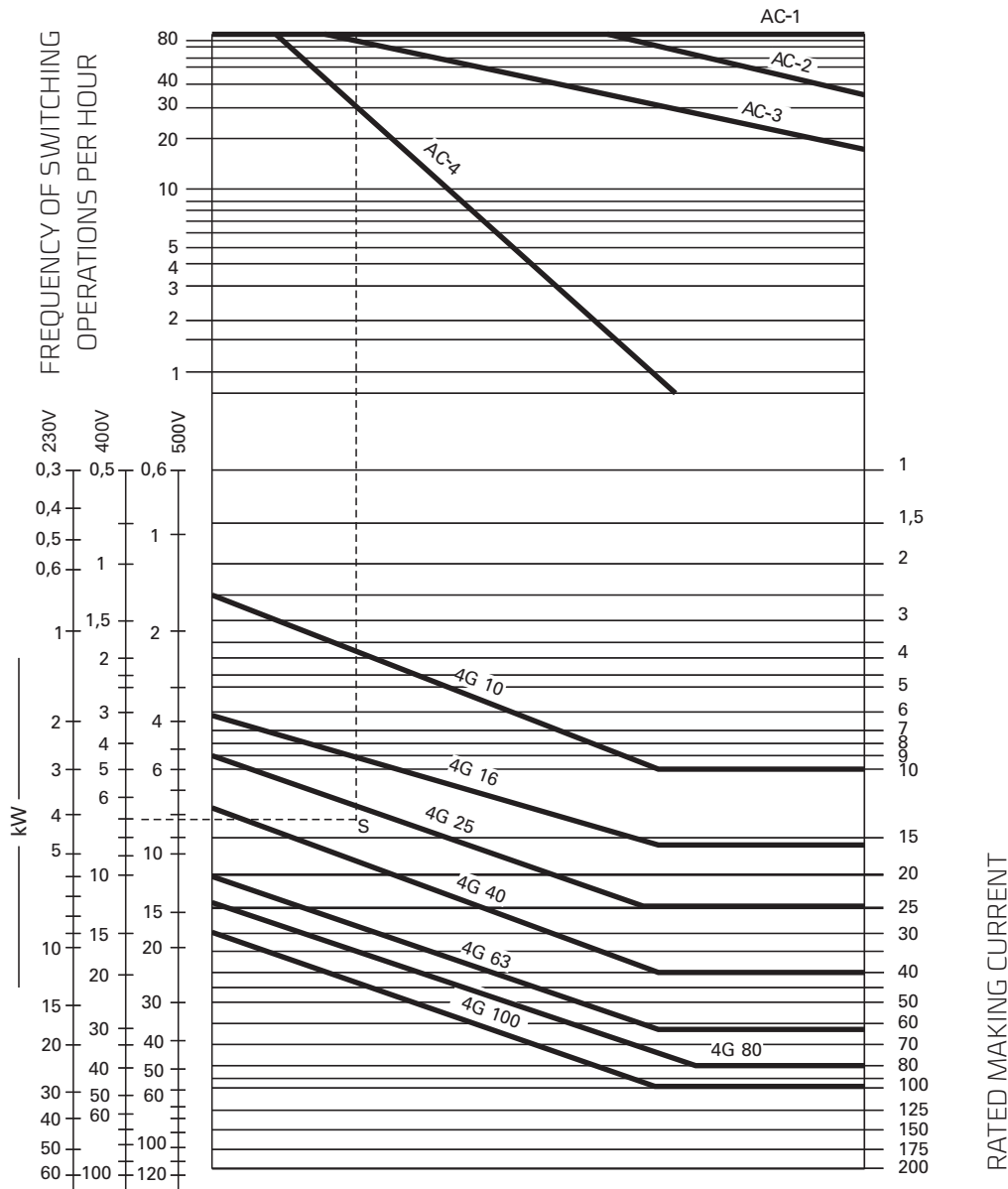

Diagram application example:

The task is to select a cam switch for direct switching and counter-current braking of a squirrel-cage motor characterized by the rated power 7 kW, 380 V and 30 switching operations per hour:

1. Utilization category: AC-4.
2. Find the number of switching operations in the diagram: 30 per hour /in the top part of the diagram/.
3. Draw a horizontal line from the point you have found from the point of intersection with relevant utilization category (AC-4).
4. In the bottom part of the diagram, find the motor power (7 kW, 380 V) on the scale of proper voltage and draw a horizontal line to the right.
5. Draw a perpendicular line down from the point of intersection of the top horizontal line with the utilization category line (AC-4).
6. The point of intersection with the bottom horizontal line "S" lies in the area related to the switch type you are looking for (4G 40).

ORDER FORM

87-100 Toruń, ul. Gdańska nr 4a lok. C4 SWITCHING EQUIPMENT SALES OFFICE Phones: 48 (56) 61 91 627, 48 (56) 61 91 316 e-mail: trade@apator.com www.apator.com	Contracting party: Address: Phone: Fax: e-mail:
---	---

Technical data Ue.....V~ Ue.....V= Ie.....A <div style="border: 1px solid black; padding: 5px; width: 100px; height: 100px; margin: 5px auto;"> Number of pieces </div>	Type of assembly 	Type and colour of a knob or a handle Black <input type="checkbox"/> Red <input type="checkbox"/> Black <input type="checkbox"/> Red <input type="checkbox"/>	Knob rotation angle <input type="checkbox"/> 30° <input type="checkbox"/> 45° A0/A1/A2/A3 A0/A1/A2 <input type="checkbox"/> 60° <input type="checkbox"/> 60° A0/A1/A2/A3 A0/A1/A2/A3 <input type="checkbox"/> 90° A0/A1/A2/A3 	Special version <table border="1" style="width: 100%; border-collapse: collapse; text-align: center;"> <tr><td>S1</td><td>S17</td></tr> <tr><td>S5</td><td>S18</td></tr> <tr><td>S6</td><td>S19</td></tr> <tr><td>S7</td><td>S21</td></tr> <tr><td>S8</td><td>S22</td></tr> <tr><td>S9</td><td>S24</td></tr> <tr><td>S10</td><td>S25</td></tr> <tr><td>S11</td><td>S29</td></tr> <tr><td>S12</td><td>S30</td></tr> <tr><td>S15</td><td></td></tr> </table>	S1	S17	S5	S18	S6	S19	S7	S21	S8	S22	S9	S24	S10	S25	S11	S29	S12	S30	S15	
S1	S17																							
S5	S18																							
S6	S19																							
S7	S21																							
S8	S22																							
S9	S24																							
S10	S25																							
S11	S29																							
S12	S30																							
S15																								

Indicating plate description example 	Notes: Switching diagram:
Position descriptions on the indicating plate, according to the angle of rotation.	

Description of the indicating plate according to customer's requirements. (to be entered in the adjacent fields)	1	A																																													
	2	B																																													
	3																																														
	4	C																																													
	5	D																																													
	6																																														
	7																																														
	8																																														
	9																																														
	10																																														
	11																																														
	12																																														

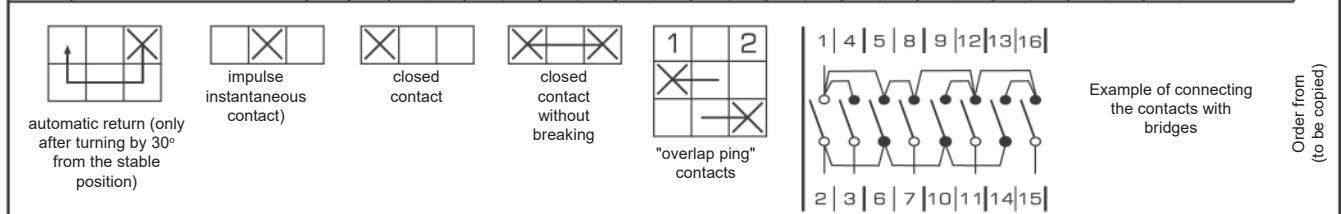

ORDER FORM

Order form (to be copied)