

Class I, II, Compact multi-pole SPD 12.5 kA per pole

Page 8-2



- Class I, II / Type 1,2 / B, C
- Main distribution boards
- L/N-PE, L-PEN, L-N, N-PE
- High energy MOV and GDT
- $I_{imp} = 12.5 \text{ kA}$
- Separate thermal disconnector for each MOV
- IEC/EN 61643-11

Class I, II, Compact single and multi-pole SPD 25 kA per pole

Page 8-4



- Class I, II / Type 1,2 / B, C
- Main distribution boards
- L/N-PE, L-PEN, L-N, N-PE
- High energy MOV and GDT
- I_{imp} up to 50 kA
- Separate thermal disconnector for each MOV
- IEC/EN 61643-11

Class II, Modular single and multi-pole SPD 40 kA per pole

Page 8-7



- Class II / Type 2 / C
- Sub-distribution boards
- L/N-PE, L-PEN, L-N, N-PE
- MOV and GDT
- $I_{max} = 40 \text{ kA}$
- Separate thermal disconnector for each MOV
- IEC/EN 61643-11

Class II, Modular multi-pole SPD up to 40 kA per pole

Page 8-7

- Class II / Type 2 / C
- Sub-distribution boards
- L/N-PE, L-PEN, L-N, N-PE
- MOV and GDT
- I_{max} up to 40 kA
- Separate thermal disconnector for each MOV
- IEC/EN 61643-11

Class I, II, SPD for Photovoltaic systems

Page 8-9



- Class I, II / Type 1, 2 / B, C
- Photovoltaic systems - PV module side
- (+) PE, (-) PE, (+) (-)
- High energy MOV and GDT
- $I_{imp} = 12.5 \text{ kA}$; I_{max} up to 40 kA
- Ground fault immunity, ground fault withstand
- Separate thermal disconnector for each MOV
- EN 50539-11, UL 1449 3rd Ed

Class I, II, SPD for Wind systems

Page 8-11



- Class I, II / Type 1, 2 / B+C
- Distribution boards
- L/N-PER, L-PEN
- High energy MOV and GDT
- TOV immunity, TOV withstand for unlimited time
- Separate thermal disconnector for each MOV
- IEC/EN 50539-11, UL 1449 3rd Ed

Class II, SPD for Overhead power lines

Page 8-13



- Class II / Type 2 / A
- Overhead power lines
- L/N-PE
- MOV
- I_{max} up to 40 kA
- Thermal disconnector
- IEC/EN 61643-11

SURGE PROTECTIVE DEVICES ARE DESIGNED TO PROTECT AGAINST TRANSIENT SURGE CONDITIONS. LARGE SINGLE SURGE EVENTS, SUCH AS LIGHTNING, CAN REACH HUNDREDS OF THOUSANDS OF VOLTS AND CAN CAUSE IMMEDIATE OR INTERMITTENT EQUIPMENT FAILURE

OVERVOLTAGE PROTECTION - ISPRO-K BS(R)

CLASS I, II COMPACT MULTI-POLE SPD; $I_{imp} = 12.5 \text{ kA (10/350) PER POLE}$



The ISPRO-K BS(R) is a compact, multi-pole housing design and consists of a high performance varistors with thermal disconnection mechanism.

BENEFITS

- Category IEC / EN / VDE
- Location of use
- Protection modes
- Protective elements
- Surge discharge rating
- Internal protection and safety
- Complies with

Class I, II / Type 1, 2 / B, C
Main distribution boards
L/N-PE, L-PEN, L-N, N-PE
High energy MOV and GDT
 $I_{imp} = 12.5 \text{ kA}$
Separate thermal disconnecter for each MOV
IEC/EN 61643-11

ORDERING DATA

Overvoltage protection - ISPRO-K BS(R)	page 8-3
Accessories	page 8-11
Connections	page 8-27
Example - Ordering data	page 8-5
Technical characteristics	page 8-13
Dimensions	page 8-25

OVERVOLTAGE PROTECTION - ISPRO-K BS(R)

CLASS I, II COMPACT MULTI-POLE SPD; $I_{imp} = 12.5 \text{ kA}$ (10/350) PER POLE

ISPRO-K BS(R) 37.5/xxx (3+0)

Type	Max. discharge current (8/20) I_{max} (kA)	Impulse current (10/350) I_{imp} (kA)	Ordering No.	Weight (g)	Packaging (pcs)
ISPRO-K BS 37.5/150 (3+0)	50 per pole	12.5 per pole	786.600.051	300	5
ISPRO-K BS 37.5/275 (3+0)	50 per pole	12.5 per pole	786.600.052	382	5
ISPRO-K BS 37.5/320 (3+0)	50 per pole	12.5 per pole	786.600.053	382	5
ISPRO-K BS 37.5/385 (3+0)	50 per pole	12.5 per pole	786.600.054	394	5
ISPRO-K BS 37.5/440 (3+0)	50 per pole	12.5 per pole	786.600.055	432	5
ISPRO-K BSR 37.5/150 (3+0)	50 per pole	12.5 per pole	786.600.056	305	5
ISPRO-K BSR 37.5/275 (3+0)	50 per pole	12.5 per pole	786.600.057	387	5
ISPRO-K BSR 37.5/320 (3+0)	50 per pole	12.5 per pole	786.600.058	387	5
ISPRO-K BSR 37.5/385 (3+0)	50 per pole	12.5 per pole	786.600.059	399	5
ISPRO-K BSR 37.5/440 (3+0)	50 per pole	12.5 per pole	786.600.060	437	5

ISPRO-K BS(R) 50/xxx (4+0)

Type	Max. discharge current (8/20) I_{max} (kA)	Impulse current (10/350) I_{imp} (kA)	Ordering No.	Weight (g)	Packaging (pcs)
ISPRO-K BS 50/150 (4+0)	50 per pole	12.5 per pole	786.600.061	366	3
ISPRO-K BS 50/275 (4+0)	50 per pole	12.5 per pole	786.600.062	462	3
ISPRO-K BS 50/320 (4+0)	50 per pole	12.5 per pole	786.600.063	462	3
ISPRO-K BS 50/385 (4+0)	50 per pole	12.5 per pole	786.600.064	494	3
ISPRO-K BS 50/440 (4+0)	50 per pole	12.5 per pole	786.600.065	526	3
ISPRO-K BSR 50/150 (4+0)	50 per pole	12.5 per pole	786.600.066	371	3
ISPRO-K BSR 50/275 (4+0)	50 per pole	12.5 per pole	786.600.067	467	3
ISPRO-K BSR 50/320 (4+0)	50 per pole	12.5 per pole	786.600.068	467	3
ISPRO-K BSR 50/385 (4+0)	50 per pole	12.5 per pole	786.600.069	499	3
ISPRO-K BSR 50/440 (4+0)	50 per pole	12.5 per pole	786.600.070	531	3

CLASS I, II COMPACT MULTI-POLE SPD; $I_{imp} = 12.5 \text{ kA}/50 \text{ kA}$ (10/350) L-N/N-PE

ISPRO-K BS(R) 50/xxx (3+1)

Type	Max. discharge current (8/20) I_{max} (kA)	Impulse current (10/350) I_{imp} (kA)	Ordering No.	Weight (g)	Packaging (pcs)
ISPRO-K BS 50/150 (3+1)	50 per pole	12.5 per pole	786.600.071	442	3
ISPRO-K BS 50/275 (3+1)	50 per pole	12.5 per pole	786.600.072	538	3
ISPRO-K BS 50/320 (3+1)	50 per pole	12.5 per pole	786.600.073	538	3
ISPRO-K BS 50/385 (3+1)	50 per pole	12.5 per pole	786.600.074	548	3
ISPRO-K BS 50/440 (3+1)	50 per pole	12.5 per pole	786.600.075	577	3
ISPRO-K BSR 50/150 (3+1)	50 per pole	12.5 per pole	786.600.076	447	3
ISPRO-K BSR 50/275 (3+1)	50 per pole	12.5 per pole	786.600.077	543	3
ISPRO-K BSR 50/320 (3+1)	50 per pole	12.5 per pole	786.600.078	543	3
ISPRO-K BSR 50/385 (3+1)	50 per pole	12.5 per pole	786.600.079	553	3
ISPRO-K BSR 50/440 (3+1)	50 per pole	12.5 per pole	786.600.080	582	3

OVERVOLTAGE PROTECTION - ISPRO-K BS(R)

CLASS I, II COMPACT MULTI-POLE SPD; $I_{imp} = 12.5 \text{ kA (10/350) PER POLE}$

BENEFITS

- Category IEC / EN / VDE
 - Location of use
 - Network systems
 - Protection modes
 - Protective elements
 - Surge discharge rating
 - MOV max. withstand capability 1x8/20
 - Housing
 - Complies with
- Class I, II / Type 1, 2 / B, C
Main distribution boards
TN-C, IT
L-PEN
High energy MOV
 $I_{imp} = 12.5 \text{ kA}$
100 kA per pole
Compact design
IEC/EN 61643-11

Type	Symbol	Unit	ISPRO-K BS(R) 37.5/xxx (3+0)				
			150	275	320	385	440
ELECTRICAL CHARACTERISTICS							
Max. continuous operating voltage (AC/DC)	U_c	V	150/200	275/350	320/420	385/500	440/580
Nominal discharge current (8/20)	I_n	kA	20 per pole				
Max. discharge current (8/20)	I_{max}	kA	50 per pole				
Impulse current (10/350)	I_{imp}	kA	12.5 per pole				
Specific energy	W/R	J/Ω	39				
Charge	Q	As	6.25				
Protection level	U_p	kV	<0.9	<1.4	<1.4	<1.8	<2.1
Residual voltage at I_{imp}	U_{res}	kV	<0.7	<1.2	<1.2	<1.5	<1.8
Residual voltage at 5 kA (8/20)	U_{res}	kV	<0.6	<1.1	<1.1	<1.2	<1.3
Follow current	I_{fi}		NO				
Response time	t_A	ns	<25				
Thermal protection			Yes				
Back-up fuse (if mains >250 A)			250 A gL				
Short-circuit withstand current (50 Hz)	I_{SCCR}	kA	25				
MECHANICAL CHARACTERISTICS							
Dimensions DIN 43880			3TE				
Temperature range		°C	-40 ... 80				
Terminal screw torque		Nm	max. 3				
Terminal cross section		mm ²	35 (solid) / 25 (stranded)				
Mounting			35 mm DIN rail acc. to EN 60715				
Degree of protection			IP 20				
Housing material			Thermoplastic; extinguishing degree UL 94 V-0				
Indication material			Red flag				
Remote contacts (RC)			Yes				
Contact ratings			AC: 250 V / 0.5 A; 125 V / 3 A				
Terminal cross section		mm ²	max. 1.5				
Remote terminal torque		Nm	0.25				

OVERVOLTAGE PROTECTION - ISPRO-K BS(R)

CLASS I, II COMPACT MULTI-POLE SPD; $I_{imp} = 12.5 \text{ kA (10/350) PER POLE}$

BENEFITS

- Category IEC / EN / VDE
 - Location of use
 - Network systems
 - Protection modes
 - Protective elements
 - Surge discharge rating
 - MOV max. withstand capability 1x8/20
 - Housing
 - Complies with
- Class I, II / Type 1, 2 / B, C
Main distribution boards
TN-S, IT
L/N-PE
High energy MOV
 $I_{imp} = 12.5 \text{ kA}$
100 kA per pole
Compact design
IEC/EN 61643-11

Type	Symbol	Unit	ISPRO-K BS(R) 37.5/xxx (4+0)				
			150	275	320	385	440
ELECTRICAL CHARACTERISTICS							
Max. continuous operating voltage (AC/DC)	U_c	V	150/200	275/350	320/420	385/500	440/580
Nominal discharge current (8/20)	I_n	kA	20 per pole				
Max. discharge current (8/20)	I_{max}	kA	50 per pole				
Impulse current (10/350)	I_{imp}	kA	12.5 per pole				
Specific energy	W/R	J/Ω	39				
Charge	Q	As	6.25				
Protection level	U_p	kV	<0.9	<1.4	<1.4	<1.8	<2.1
Residual voltage at I_{imp}	U_{res}	kV	<0.8	<1.3	<1.3	<1.6	<1.9
Residual voltage at 5 kA (8/20)	U_{res}	kV	<0.6	<1.1	<1.1	<1.2	<1.3
Follow current	I_f		NO				
Response time	t_A	ns	<25				
Thermal protection			Yes				
Back-up fuse (if mains >250 A)			250 A gL				
Short-circuit withstand current (50 Hz)	I_{SCCR}	kA	25				
MECHANICAL CHARACTERISTICS							
Dimensions			4TE				
Temperature range		°C	-40 80				
Terminal screw torque		Nm	max. 3				
Terminal cross section		mm ²	35 (solid) / 25 (stranded)				
Mounting			35 mm DIN rail acc. to EN 60715				
Degree of protection			IP 20				
Housing material			Thermoplastic; extinguishing degree UL 94 V-0				
Indication material			Red flag				
Remote contacts (RC)			Yes				
Contact ratings			AC: 250 V / 0.5 A; 125 V / 3 A				
Terminal cross section		mm ²	max. 1.5				
Remote terminal torque		Nm	0.25				

OVERVOLTAGE PROTECTION - ISPRO-K BS(R)

CLASS I, II COMPACT MULTI-POLE SPD; $I_{imp} = 12.5 \text{ kA}/50 \text{ kA} (10/350) \text{ L-N/N-PE}$

BENEFITS

- Category IEC / EN / VDE
 - Location of use
 - Network systems
 - Protection modes
 - Protective elements
 - Surge discharge rating
 - MOV max. withstand capability 1x8/20
 - Housing
 - Complies with
- Class I, II / Type 1, 2 / B, C
Main distribution boards
TT, TN-S
L-N, N-PE
High energy MOV and GDT
 $I_{imp} = 12.5 \text{ kA}/50 \text{ kA} (L-N/M-PE)$
100 kA per pole
Compact design
IEC/EN 61643-11

Type	Symbol	Unit	ISPRO-K BS(R) 37.5/xxx (3+1)					
			150	275	320	385	440	
ELECTRICAL CHARACTERISTICS								
Max. continuous operating voltage (AC/DC)	(L-N) (N-PE)	U_c	V	150/200	275/350	320/420 255	385/500	440/580
Nominal discharge current (8/20)	(L-N/N-PE)	I_n	kA			20/50		
Max. discharge current (8/20)	(L-N/N-PE)	I_{max}	kA			50/100		
Impulse current (10/350)	(L-N/N-PE)	I_{imp}	kA			12.5/50		
Specific energy	(L-N/N-PE)	W/R	J/ Ω			39/625		
Charge	(L-N/N-PE)	Q	As			6.25/25		
Protection level	(L-N) (N-PE)	U_p	kV	<0.9	<1.4	<1.4 <1.5	<1.8	<2.1
Residual voltage at I_{imp}	(L-N)	U_{res}	kV	<0.7	<1.2	<1.2	<1.5	<1.8
Residual voltage at 5 kA (8/20)	(L-N)	U_{res}	kV	<0.6	<1.1	<1.1	<1.2	<1.3
Follow current	(PE)	I_{fi}	A _{RMS}			100		
Response time	(L-N/N-PE)	t_a	ns			<25/100		
Thermal protection	(L-N)					Yes		
Back-up fuse (if mains >250 A)	(L-N)					250 A gL		
Short-circuit withstand current (50 Hz)	(L-N)	I_{SCCR}	kA			25		
MECHANICAL CHARACTERISTICS								
Dimensions						4TE		
Temperature range			°C			-40 ... 80		
Terminal screw torque			Nm			max. 3		
Terminal cross section			mm ²			35 (solid) / 25 (stranded)		
Mounting						35 mm DIN rail acc. to EN 60715		
Degree of protection						IP 20		
Housing material						Thermoplastic; extinguishing degree UL 94 V-0		
Indication material						Red flag		
Remote contacts (RC)						Yes		
Contact ratings						AC: 250 V / 0.5 A; 125 V / 3 A		
Terminal cross section			mm ²			max. 1.5		
Remote terminal torque			Nm			0.25		

OVERVOLTAGE PROTECTION - ISPRO-K BS(R)

Network connections

TN-S Network - Single-phase (T-connection)

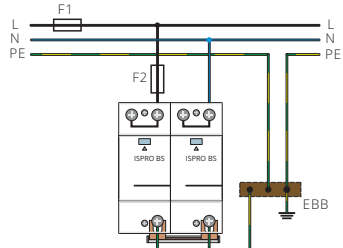

TN-S Network - Single-phase (V-connection)

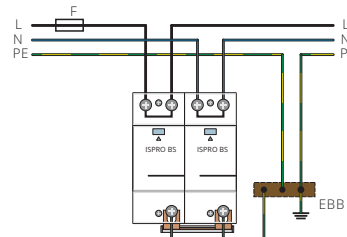

TN-C Network - Three-phase (T-connection)

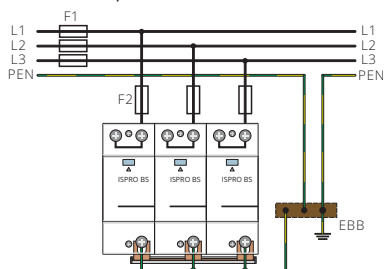

TN-C Network - Three-phase (V-connection)

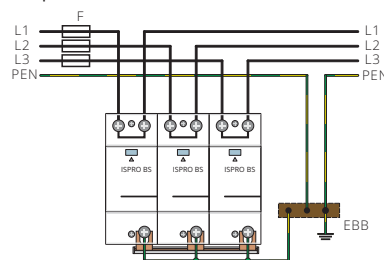

TN-S Network - Three-phase (T-connection)

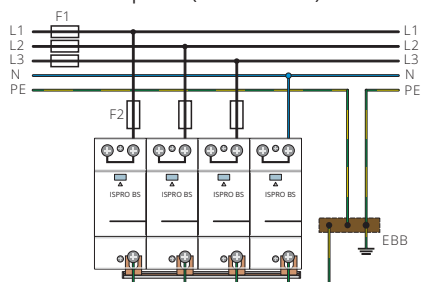

TN-S Network - Three-phase (V-connection)

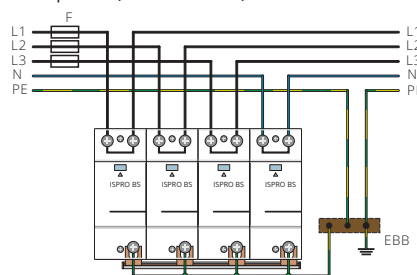

IT Network - Three-phase (T-connection)

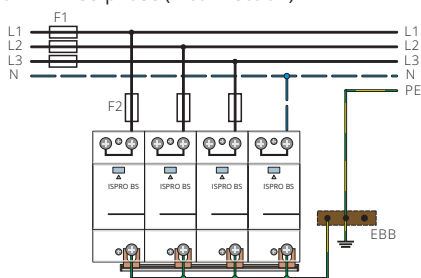

IT Network - Three-phase (V-connection)

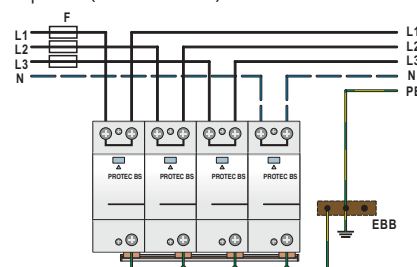

$$U_c \geq 1.1 \cdot U_n \cdot \sqrt{3}$$

Back-up fuse

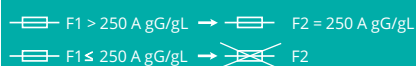

OVERVOLTAGE PROTECTION - ISPRO-K BS(R)

ISPRO BS(R) 37.5/xxx (3+0)

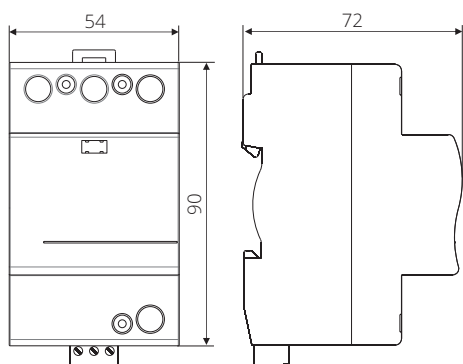

Internal configuration

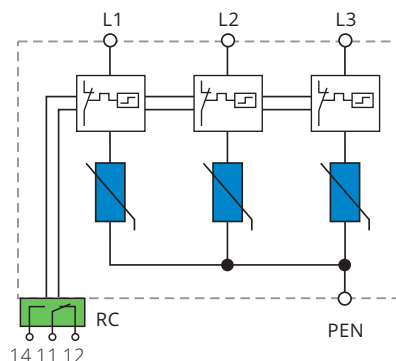

ISPRO-K BS(R) 50/xxx (4+0)

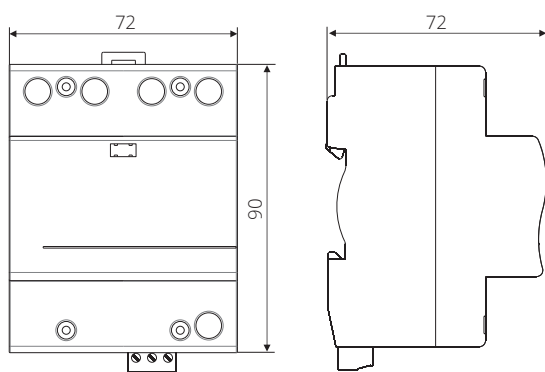

Internal configuration

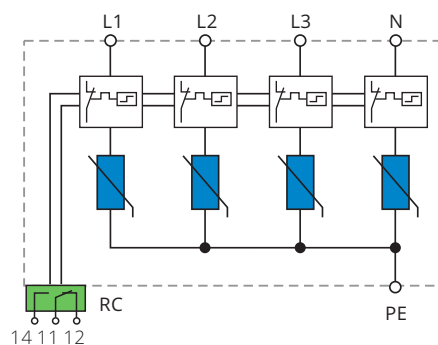

ISPRO-K BS(R) 25/xxx (1+1)

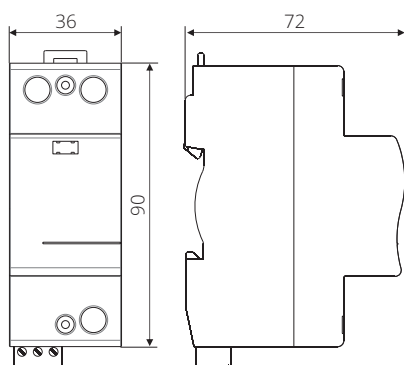

Internal configuration

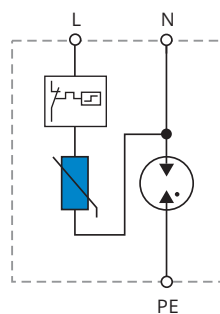

OVERVOLTAGE PROTECTION - ISPRO-K BS(R)

ISPRO BS(R) 50/xxx (3+1)

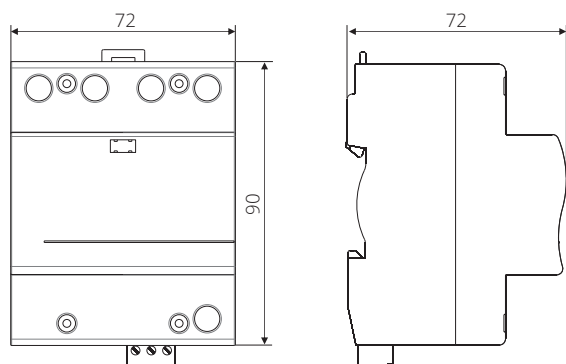

Internal configuration

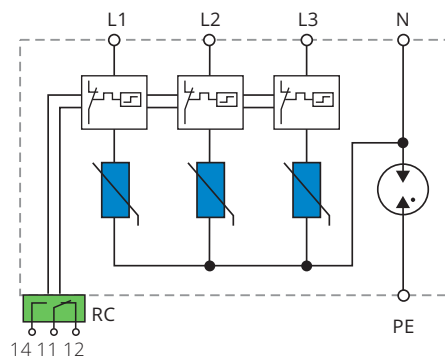

OVERVOLTAGE PROTECTION - ISPRO BS(R), ISPRO-K BS(R)

CLASS I, II COMPACT SINGLE AND MULTI-POLE SPD 25 kA PER POLE



The ISPRO BS(R) 25 kA per pole series of overvoltage surge protective devices have been developed to protect against partial direct and indirect lightning discharges. They are suited for power supply installations and intended to provide protection in zones 0_A - 2 per IEC 62305.

BENEFITS

- Category IEC / EN / VDE
- Location of use
- Protection modes
- Protective elements
- Surge discharge rating
- Internal protection and safety
- Complies with

Class I, II / Type 1, 2 / B, C
Main distribution boards
L/N-PE, L-PEN, L-N, N-PE
High energy MOV and GDT
 I_{imp} up to 50 kA
Separate thermal disconnecter for each MOV
IEC/EN 61643-11

ORDERING DATA

Overvoltage protection - ISPRO BS(R)	page 8-10
Connections	page 8-16
Example - Ordering data	page 8-13
Technical characteristics	page 8-14
Dimensions	page 8-17

OVERVOLTAGE PROTECTION - ISPRO BS(R), ISPRO-K BS(R)

CLASS I, II COMPACT SINGLE-POLE SPD; $I_{imp} = 25 \text{ kA (10/350)}$

ISPRO BS(R) 25/xxx

Type	Max. discharge current (8/20) I_{max} (kA)	Impulse current (10/350) I_{imp} (kA)	Ordering No.	Weight (g)	Packaging (pcs)
ISPRO BS 25/150	100	25	786.600.010	200	7
ISPRO BS 25/275	100	25	786.600.011	252	7
ISPRO BS 25/320	100	25	786.600.012	252	7
ISPRO BS 25/385	100	25	786.600.013	268	7
ISPRO BS 25/440	100	25	786.600.014	285	7
ISPRO BSR 25/150	100	25	786.600.015	205	7
ISPRO BSR 25/275	100	25	786.600.016	257	7
ISPRO BSR 25/320	100	25	786.600.017	257	7
ISPRO BSR 25/385	100	25	786.600.018	273	7
ISPRO BSR 25/440	100	25	786.600.019	289	7

CLASS I, II COMPACT MULTI-POLE SPD; $I_{imp} = 25 \text{ kA (10/350)}$ PER POLE

ISPRO-K BS(R) 75/xxx (3+0)

Type	Max. discharge current (8/20) I_{max} (kA)	Impulse current (10/350) I_{imp} (kA)	Ordering No.	Weight (g)	Packaging (pcs)
ISPRO-K BS 75/150 (3+0)	100 per pole	25 per pole	786.600.021	400	5
ISPRO-K BS 75/275 (3+0)	100 per pole	25 per pole	786.600.022	570	5
ISPRO-K BS 75/320 (3+0)	100 per pole	25 per pole	786.600.023	570	5
ISPRO-K BS 75/385 (3+0)	100 per pole	25 per pole	786.600.024	726	5
ISPRO-K BS 75/440 (3+0)	100 per pole	25 per pole	786.600.025	792	5
ISPRO-K BSR 75/150 (3+0)	100 per pole	25 per pole	786.600.026	405	5
ISPRO-K BSR 75/275 (3+0)	100 per pole	25 per pole	786.600.027	575	5
ISPRO-K BSR 75/320 (3+0)	100 per pole	25 per pole	786.600.028	575	5
ISPRO-K BSR 75/385 (3+0)	100 per pole	25 per pole	786.600.029	731	5
ISPRO-K BSR 75/440 (3+0)	100 per pole	25 per pole	786.600.030	797	5

ISPRO-K BS(R) 100/xxx (4+0)

Type	Max. discharge current (8/20) I_{max} (kA)	Impulse current (10/350) I_{imp} (kA)	Ordering No.	Weight (g)	Packaging (pcs)
ISPRO-K BS 100/150 (4+0)	100 per pole	25 per pole	786.600.031	532	3
ISPRO-K BS 100/275 (4+0)	100 per pole	25 per pole	786.600.032	756	3
ISPRO-K BS 100/320 (4+0)	100 per pole	25 per pole	786.600.033	756	3
ISPRO-K BS 100/385 (4+0)	100 per pole	25 per pole	786.600.034	912	3
ISPRO-K BS 100/440 (4+0)	100 per pole	25 per pole	786.600.035	1000	3
ISPRO-K BSR 100/150 (4+0)	100 per pole	25 per pole	786.600.036	537	3
ISPRO-K BSR 100/275 (4+0)	100 per pole	25 per pole	786.600.037	761	3
ISPRO-K BSR 100/320 (4+0)	100 per pole	25 per pole	786.600.038	761	3
ISPRO-K BSR 100/385 (4+0)	100 per pole	25 per pole	786.600.039	917	3
ISPRO-K BSR 100/440 (4+0)	100 per pole	25 per pole	786.600.040	1005	3

OVERVOLTAGE PROTECTION - ISPRO BS(R), ISPRO-K BS(R)

CLASS I, II COMPACT MULTI-POLE SPD; $I_{imp} = 25 \text{ kA}/50 \text{ kA} (10/350) \text{ L-N/N-PE}$

ISPRO-K BS(R) 50/xxx (1+1)

Type	Max. discharge current (8/20) I_{max} (kA)	Impulse current (10/350) I_{imp} (kA)	Ordering No.	Weight (g)	Packaging (pcs)
ISPRO BS 50/150 (1+1)	100/100	25/50	786.600.010	308	5
ISPRO BS 50/275 (1+1)	100/100	25/50	786.600.011	364	5
ISPRO BS 50/320 (1+1)	100/100	25/50	786.600.012	364	5
ISPRO BS 50/385 (1+1)	100/100	25/50	786.600.013	386	5
ISPRO BS 50/440 (1+1)	100/100	25/50	786.600.014	408	5
ISPRO BSR 50/150 (1+1)	100/100	25/50	786.600.015	313	5
ISPRO BSR 50/275 (1+1)	100/100	25/50	786.600.016	369	5
ISPRO BSR 50/320 (1+1)	100/100	25/50	786.600.017	369	5
ISPRO BSR 50/385 (1+1)	100/100	25/50	786.600.018	391	5
ISPRO BSR 50/440 (1+1)	100/100	25/50	786.600.019	414	5

CLASS I, II COMPACT MULTI-POLE SPD; $I_{imp} = 25 \text{ kA}/100 \text{ kA} (10/350) \text{ L-N/N-PE}$

ISPRO-K BS(R) 100/xxx (3+1)

Type	Max. discharge current (8/20) I_{max} (kA)	Impulse current (10/350) I_{imp} (kA)	Ordering No.	Weight (g)	Packaging (pcs)
ISPRO-K BS 100/150 (3+1)	100/100	25/100	786.600.041	568	3
ISPRO-K BS 100/275 (3+1)	100/100	25/100	786.600.042	728	3
ISPRO-K BS 100/320 (3+1)	100/100	25/100	786.600.043	728	3
ISPRO-K BS 100/385 (3+1)	100/100	25/100	786.600.176	834	3
ISPRO-K BS 100/440 (3+1)	100/100	25/100	786.600.177	900	3
ISPRO-K BSR 100/150 (3+1)	100/100	25/100	786.600.046	573	3
ISPRO-K BSR 100/275 (3+1)	100/100	25/100	786.600.047	733	3
ISPRO-K BSR 100/320 (3+1)	100/100	25/100	786.600.048	733	3
ISPRO-K BSR 100/385 (3+1)	100/100	25/100	786.600.178	839	3
ISPRO-K BSR 100/440 (3+1)	100/100	25/100	786.600.179	905	3

OVERVOLTAGE PROTECTION - ISPRO BS(R)

CLASS I, II COMPACT SINGLE-POLE SPD; $I_{imp} = 25 \text{ kA (10/350)}$

BENEFITS

- Category IEC / EN / VDE
 - Location of use
 - Network systems
 - Protection modes
 - Protective elements
 - Surge discharge rating
 - MOV max. withstand capability 1x8/20
 - Housing
 - Complies with
- Class I, II / Type 1, 2 / B, C
Main distribution boards
TN-S, TN-C, IT
L/N-PE, L-PEN
High energy MOV
 $I_{imp} = 25 \text{ kA}$
120 kA
Compact design
IEC/EN 61643-11

Type	Symbol	Unit	ISPRO BS(R) 25/xxx				
			150	275	320	385	440
ELECTRICAL CHARACTERISTICS							
Max. continuous operating voltage (AC/DC)	U_c	V	150/200	275/350	320/420	385/500	440/580
Nominal discharge current (8/20)	I_n	kA			25		
Max. discharge current (8/20)	I_{max}	kA			100		
Impulse current (10/350)	I_{imp}	kA			25		
Specific energy	W/R	J/Ω			156		
Charge	Q	As			12.5		
Protection level	U_p	kV	<0.7	<1.3	<1.3	<1.7	<2.0
Residual voltage at I_{imp}	U_{res}	kV	<0.7	<1.2	<1.2	<1.5	<1.8
Residual voltage at 5 kA (8/20)	U_{res}	kV	<0.5	<1.0	<1.0	<1.1	<1.2
Follow current	I_{fi}				NO		
Response time	t_A	ns			<25		
Thermal protection					Yes		
Back-up fuse (if mains >250 A)					250 A gL		
Short-circuit withstand current (50 Hz)	I_{SCCR}	kA			25		
MECHANICAL CHARACTERISTICS							
Dimensions DIN 43880					2TE		
Temperature range		°C			-40 ... 80		
Terminal screw torque		Nm			max. 3		
Terminal cross section		mm ²			35 (solid) / 25 (stranded)		
Mounting					35 mm DIN rail acc. to EN 60715		
Degree of protection					IP 20		
Housing material					Thermoplastic; extinguishing degree UL 94 V-0		
Indication material					Red flag		
Remote contacts (RC)					Yes		
Contact ratings					AC: 250 V / 0.5 A; 125 V / 3 A		
Terminal cross section		mm ²			max. 1.5		
Remote terminal torque		Nm			0.25		

OVERVOLTAGE PROTECTION - ISPRO-K BS(R)

CLASS I, II COMPACT MULTI-POLE SPD; $I_{imp} = 25 \text{ kA (10/350) PER POLE}$

BENEFITS

- Category IEC / EN / VDE
 - Location of use
 - Network systems
 - Protection modes
 - Protective elements
 - Surge discharge rating
 - MOV max. withstand capability 1x8/20
 - Housing
 - Complies with
- Class I, II / Type 1, 2 / B, C
Main distribution boards
TN-C, IT
L-PEN
High energy MOV
 $I_{imp} = 25 \text{ kA}$
150 kA per pole
Compact design
IEC/EN 61643-11

Type	Symbol	Unit	ISPRO-K BS(R) 75/xxx (3+0)				
			150	275	320	385	440
ELECTRICAL CHARACTERISTICS							
Max. continuous operating voltage (AC/DC)	U_c	V	150/200	275/350	320/420	385/500	440/580
Nominal discharge current (8/20)	I_n	kA	25 per pole				
Max. discharge current (8/20)	I_{max}	kA	100 per pole				
Impulse current (10/350)	I_{imp}	kA	25 per pole				
Specific energy	W/R	J/Ω	156				
Charge	Q	As	12.5				
Protection level	U_p	kV	<0.8	<1.4	<1.4	<1.9	<2.2
Residual voltage at I_{imp}	U_{res}	kV	<0.8	<1.3	<1.3	<1.6	<1.9
Residual voltage at 5 kA (8/20)	U_{res}	kV	<0.6	<1.0	<1.0	<1.1	<1.2
Follow current	I_{fi}		NO				
Response time	t_A	ns	<25				
Thermal protection			Yes				
Back-up fuse (if mains >250 A)			250 A gL				
Short-circuit withstand current (50 Hz)	I_{SCCR}	kA	25				
MECHANICAL CHARACTERISTICS							
Dimensions DIN 43880			3TE		8TE		
Temperature range		°C	-40 80				
Terminal screw torque		Nm	max. 3				
Terminal cross section		mm ²	35 (solid) / 25 (stranded)				
Mounting			35 mm DIN rail acc. to EN 60715				
Degree of protection			IP 20				
Housing material			Thermoplastic; extinguishing degree UL 94 V-0				
Indication material			Red flag				
Remote contacts (RC)			Yes				
Contact ratings			AC: 250 V / 0.5 A; 125 V / 3 A				
Terminal cross section		mm ²	max. 1.5				
Remote terminal torque		Nm	0.25				

OVERVOLTAGE PROTECTION - ISPRO-K BS(R)

CLASS I, II COMPACT MULTI-POLE SPD; $I_{imp} = 25 \text{ kA (10/350) PER POLE}$

BENEFITS

- Category IEC / EN / VDE
 - Location of use
 - Network systems
 - Protection modes
 - Protective elements
 - Surge discharge rating
 - MOV max. withstand capability 1x8/20
 - Housing
 - Complies with
- Class I, II / Type 1, 2 / B, C
Main distribution boards
TN-S, IT
L/N-PE
High energy MOV
 $I_{imp} = 25 \text{ kA}$
150 kA per pole
Compact design
IEC/EN 61643-11

Type	Symbol	Unit	ISPRO-K BS(R) 100/xxx (4+0)				
			150	275	320	385	440
ELECTRICAL CHARACTERISTICS							
Max. continuous operating voltage (AC/DC)	U_c	V	150/200	275/350	320/420	385/500	440/580
Nominal discharge current (8/20)	I_n	kA	25 per pole				
Max. discharge current (8/20)	I_{max}	kA	100 per pole				
Impulse current (10/350)	I_{imp}	kA	25 per pole				
Specific energy	W/R	J/Ω	156				
Charge	Q	As	12.5				
Protection level	U_p	kV	<0.8	<1.4	<1.4	<1.9	<2.2
Residual voltage at I_{imp}	U_{res}	kV	<0.8	<1.3	<1.3	<1.6	<1.9
Residual voltage at 5 kA (8/20)	U_{res}	kV	<0.6	<1.0	<1.0	<1.1	<1.2
Follow current	I_{fi}		NO				
Response time	t_a	ns	<25				
Thermal protection			Yes				
Back-up fuse (if mains >250 A)			250 A gL				
Short-circuit withstand current (50 Hz)	I_{SCCR}	kA	25				
MECHANICAL CHARACTERISTICS							
Dimensions DIN 43880			4TE		8TE		
Temperature range		°C	-40 ... 80				
Terminal screw torque		Nm	max. 3				
Terminal cross section		mm ²	35 (solid) / 25 (stranded)				
Mounting			35 mm DIN rail acc. to EN 60715				
Degree of protection			IP 20				
Housing material			Thermoplastic; extinguishing degree UL 94 V-0				
Indication material			Red flag				
Remote contacts (RC)			Yes				
Contact ratings			AC: 250 V / 0.5 A; 125 V / 3 A				
Terminal cross section		mm ²	max. 1.5				
Remote terminal torque		Nm	0.25				

OVERVOLTAGE PROTECTION - ISPRO-K BS(R)

CLASS I, II COMPACT MULTI-POLE SPD; $I_{imp} = 25 \text{ kA}/50 \text{ kA} (10/350) \text{ L-N/N-PE}$

BENEFITS

- Category IEC / EN / VDE
 - Location of use
 - Network systems
 - Protection modes
 - Protective elements
 - Surge discharge rating
 - MOV max. withstand capability 1x8/20
 - Housing
 - Complies with
- Class I, II / Type 1, 2 / B, C
Main distribution boards
TT, TN-S
L-N, N-PE
High energy MOV and GDT
 $I_{imp} = 25 \text{ kA}/50 \text{ kA} (L-N/N-PE)$
150 kA per pole
Compact design
IEC/EN 61643-11

Type	Symbol	Unit	ISPRO-K BS(R) 50/xxx (1+1)					
			150	275	320	385	440	
ELECTRICAL CHARACTERISTICS								
Max. continuous operating voltage (AC/DC)	(L-N) (N-PE)	U_c	V	150/200	275/350	320/420 255	385/500	440/580
Nominal discharge current (8/20)	(L-N/N-PE)	I_n	kA			25/50		
Max. discharge current (8/20)	(L-N/N-PE)	I_{max}	kA			100/100		
Impulse current (10/350)	(L-N/N-PE)	I_{imp}	kA			25/50		
Specific energy	(L-N/N-PE)	W/R	J/Ω			156/625		
Charge	(L-N/N-PE)	Q	As			12.5/25		
Protection level	(L-N) (N-PE)	U_p	kV	<0.8	<1.4	<1.4 <1.5	<1.8	<2.1
Residual voltage at I_{imp}	(L-N)	U_{res}	kV	<0.8	<1.3	<1.3	<1.6	<1.9
Residual voltage at 5 kA (8/20)	(L-N)	U_{res}	kV	<0.6	<1.0	<1.0	<1.1	<1.2
Follow current	(PE)	I_{fi}	A _{RMS}			100		
Response time	(L-N/N-PE)	t_a	ns			<25/100		
Thermal protection	(L-N)					Yes		
Back-up fuse (if mains >250 A)	(L-N)					250 A gL		
Short-circuit withstand current (50 Hz)	(L-N)	I_{SCCR}	kA			25		
MECHANICAL CHARACTERISTICS								
Dimensions						3TE		
Temperature range			°C			-40 ... 80		
Terminal screw torque			Nm			max. 3		
Terminal cross section			mm ²			35 (solid) / 25 (stranded)		
Mounting						35 mm DIN rail acc. to EN 60715		
Degree of protection						IP 20		
Housing material						Thermoplastic; extinguishing degree UL 94 V-0		
Indication material						Red flag		
Remote contacts (RC)						Yes		
Contact ratings						AC: 250 V / 0.5 A; 125 V / 3 A		
Terminal cross section			mm ²			max. 1.5		
Remote terminal torque			Nm			0.25		

OVERVOLTAGE PROTECTION - ISPRO-K BS(R)

CLASS I, II COMPACT MULTI-POLE SPD; $I_{imp} = 25 \text{ kA}/100 \text{ kA} (10/350) \text{ L-N/N-PE}$

BENEFITS

- Category IEC / EN / VDE
 - Location of use
 - Network systems
 - Protection modes
 - Protective elements
 - Surge discharge rating
 - MOV max. withstand capability 1x8/20
 - Housing
 - Complies with
- Class I, II / Type 1, 2 / B, C
Main distribution boards
TT, TN-S
L-N, N-PE
High energy MOV and GDT
 $I_{imp} = 25 \text{ kA}/50 \text{ kA} (L-N/N-PE)$
150 kA per pole
Compact design
IEC/EN 61643-11

Type	Symbol	Unit	ISPRO-K BS(R) 100/xxx (3+1)					
			150	275	320	385	440	
ELECTRICAL CHARACTERISTICS								
Max. continuous operating voltage (AC/DC)	(L-N) (N-PE)	U_c	V	150/200	275/350	320/420 255	385/500	440/580
Nominal discharge current (8/20)	(L-N/N-PE)	I_n	kA			25/100		
Max. discharge current (8/20)	(L-N/N-PE)	I_{max}	kA			100/100		
Impulse current (10/350)	(L-N/N-PE)	I_{imp}	kA			25/100		
Specific energy	(L-N/N-PE)	W/R	J/ Ω			156/625		
Charge	(L-N/N-PE)	Q	As			12.5/25		
Protection level	(L-N) (N-PE)	U_p	kV	<0.9	<1.4	<1.4 <1.75	<1.9	<2.2
Residual voltage at I_{imp}	(L-N)	U_{res}	kV	<0.7	<1.2	<1.2	<1.5	<1.8
Residual voltage at 5 kA (8/20)	(L-N)	U_{res}	kV	<0.5	<1.0	<1.0	<1.1	<1.2
Follow current	(PE)	I_{fi}	A _{RMS}			100		
Response time	(L-N/N-PE)	t_a	ns			<25/100		
Thermal protection	(L-N)					Yes		
Back-up fuse (if mains >250 A)	(L-N)					250 A gL		
Short-circuit withstand current (50 Hz)	(L-N)	I_{SCCR}	kA			25		
MECHANICAL CHARACTERISTICS								
Dimensions				5TE			8TE	
Temperature range			°C			-40 ... 80		
Terminal screw torque			Nm			max. 3		
Terminal cross section			mm ²			35 (solid) / 25 (stranded)		
Mounting						35 mm DIN rail acc. to EN 60715		
Degree of protection						IP 20		
Housing material						Thermoplastic; extinguishing degree UL 94 V-0		
Indication material						Red flag		
Remote contacts (RC)						Yes		
Contact ratings						AC: 250 V / 0.5 A; 125 V / 3 A		
Terminal cross section			mm ²			max. 1.5		
Remote terminal torque			Nm			0.25		

OVERVOLTAGE PROTECTION - ISPRO BS(R)

Network connections

TN-S Network - Single-phase (T-connection)

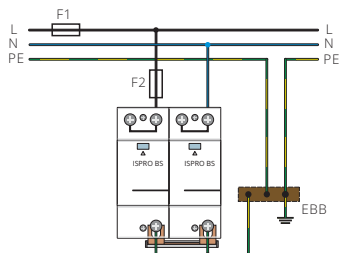

TN-S Network - Single-phase (V-connection)

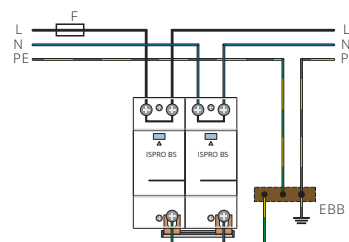

TN-C Network - Three-phase (T-connection)

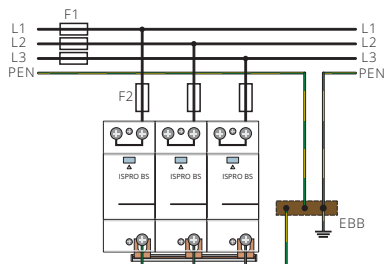

TN-C Network - Three-phase (V-connection)

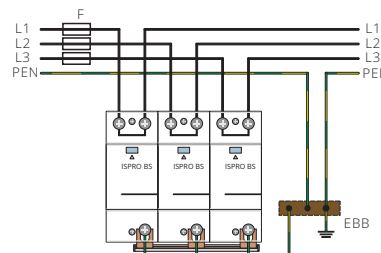

TN-S Network - Three-phase (T-connection)

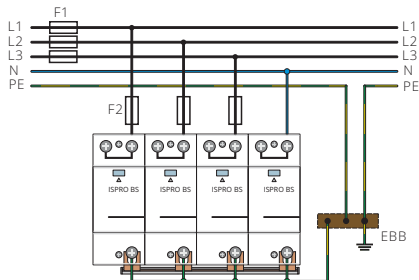

TN-S Network - Three-phase (V-connection)

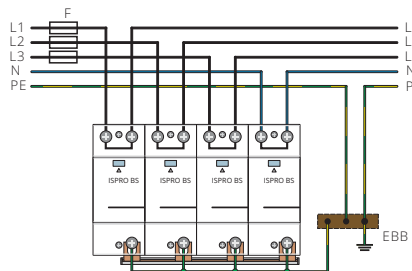

IT Network - Three-phase (T-connection)

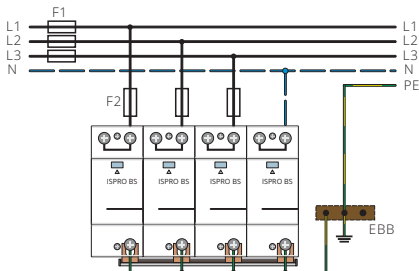



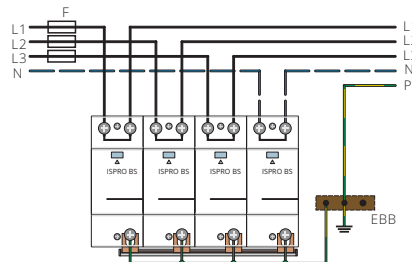

IT Network - Three-phase (V-connection)



$$U_c \geq 1.1 \cdot U_n \cdot \sqrt{3}$$

Back-up fuse

-  $F1 > 250 \text{ A gG/gL}$ →  $F2 = 250 \text{ A gG/gL}$
-  $F1 \leq 250 \text{ A gG/gL}$ →  $F2$

OVERVOLTAGE PROTECTION - ISPRO-K BS(R)

Network connections

TN-C Network - Three-phase (T-connection)

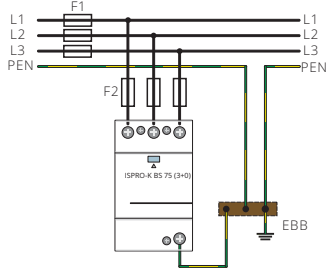

TN-C Network - Three-phase (V-connection)

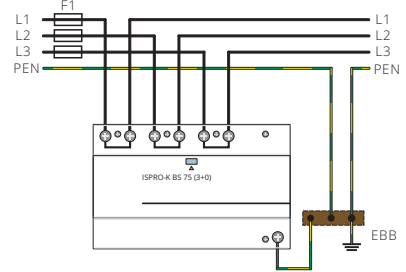

TN-S Network - Three-phase (T-connection)

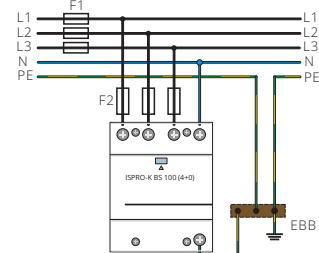

TN-S Network - Three-phase (V-connection)

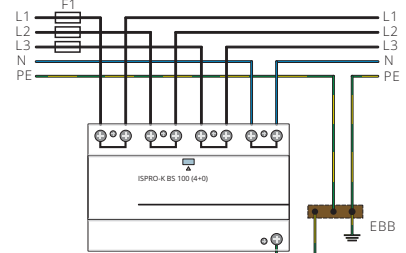

TT Network - Single-phase (T-connection)

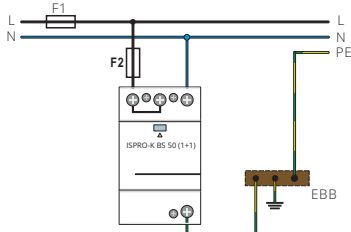

TT Network - Three-phase (T-connection)

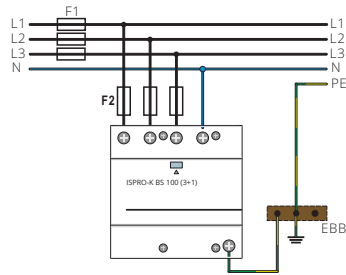

TT Network - Three-phase (V-connection)

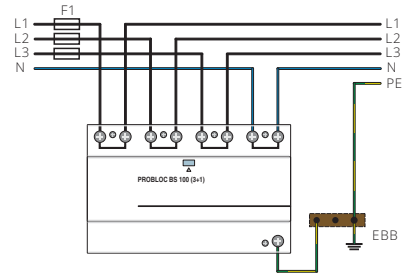

IT Network - Three-phase (T-connection)

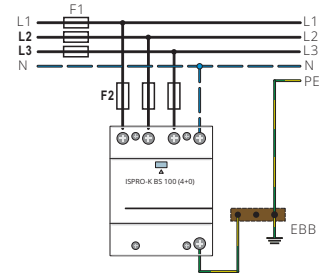

IT Network - Three-phase (V-connection)

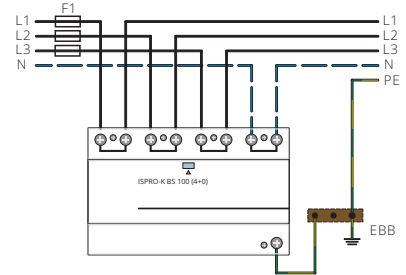

$$U_C \geq 1.1 \cdot U_n \cdot \sqrt{3}$$

Back-up fuse

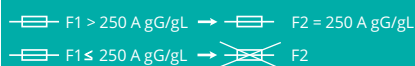

OVERVOLTAGE PROTECTION - ISPRO BS(R), ISPRO-K BS(R)

ISPRO BS(R) 25

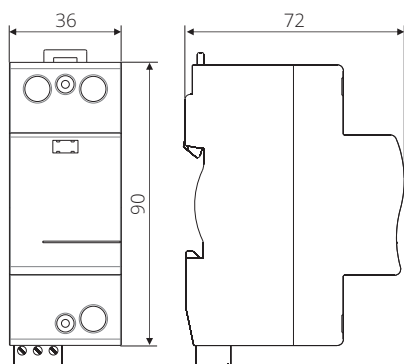

Internal configuration

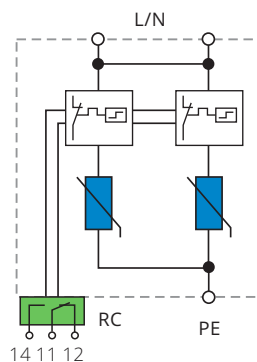

ISPRO-K BS(R) 75/150 (3+0) ISPRO-K BS(R) 75/275 (3+0) ISPRO-K BS(R) 75/320 (3+0)

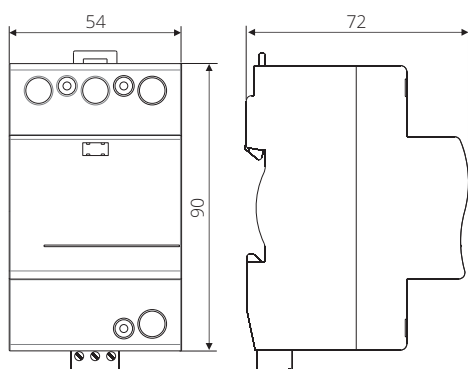

Internal configuration

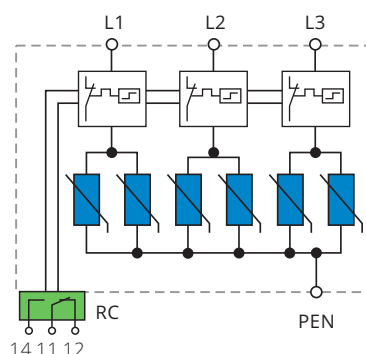

ISPRO-K BS(R) 75/385 (3+0) ISPRO-K BS(R) 75/440 (3+0)

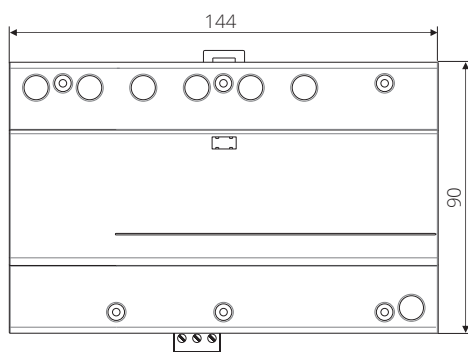

Internal configuration

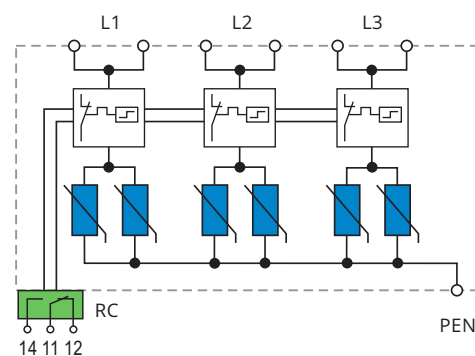

OVERVOLTAGE PROTECTION - ISPRO-K BS(R)

ISPRO-K BS(R) 100/150 (4+0)
 ISPRO-K BS(R) 100/275 (4+0)
 ISPRO-K BS(R) 100/320 (4+0)

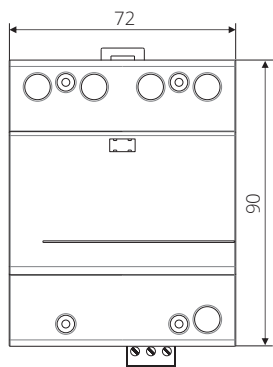

Internal configuration

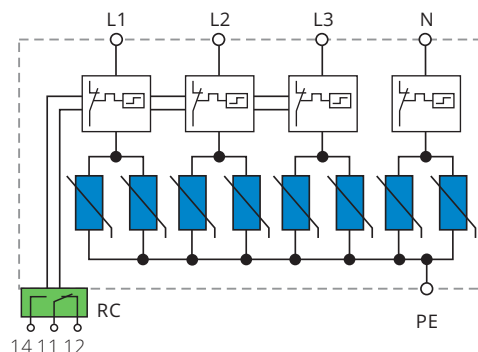

ISPRO-K BS(R) 75/385 (4+0)
 ISPRO-K BS(R) 75/440 (4+0)

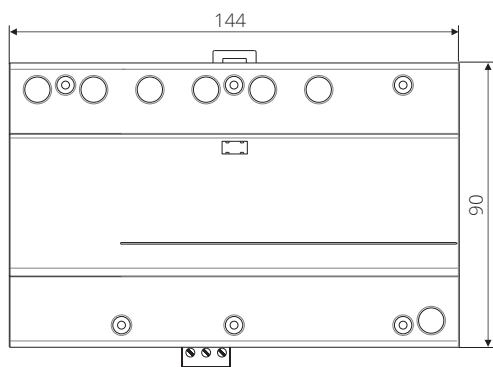

Internal configuration

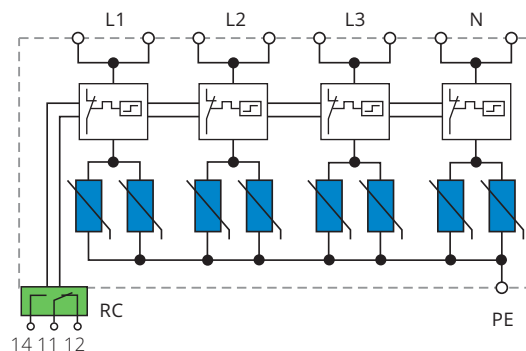

ISPRO-K BS(R) 50/xxx (1+1)

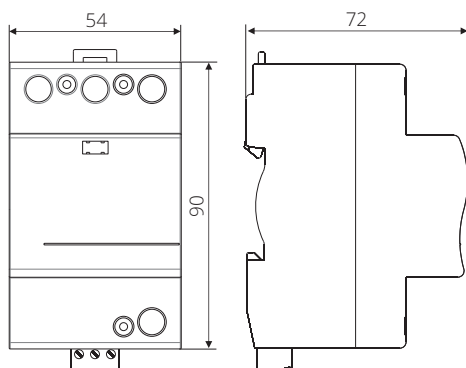

Internal configuration

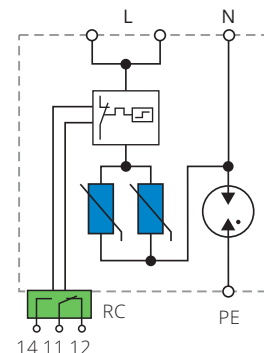

OVERVOLTAGE PROTECTION - ISPRO-K BS(R)

ISPRO-K BS(R) 100/150 (3+1)
ISPRO-K BS(R) 100/275 (3+1)
ISPRO-K BS(R) 100/320 (3+1)

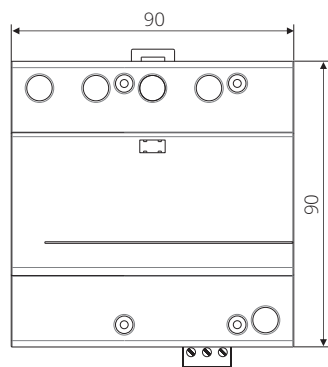

Internal configuration

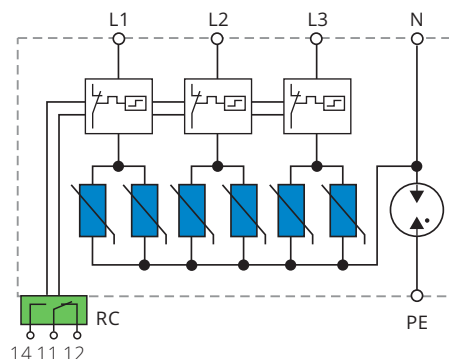

ISPRO-K BS(R) 100/385 (3+1)
ISPRO-K BS(R) 100/440 (3+1)

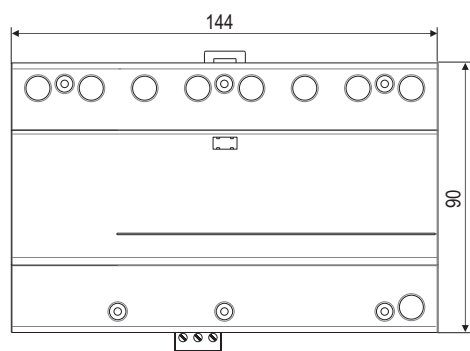

Internal configuration

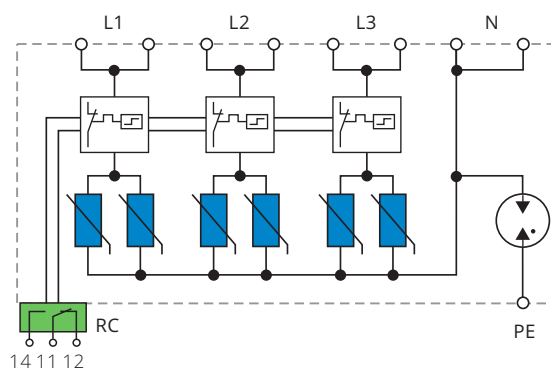

OVERVOLTAGE PROTECTION - ISPRO C(R)

CLASS II MODULAR SINGLE AND MULTI-POLE SPD 40 kA PER POLE



The ISPRO C(R) series of overvoltage surge protective devices have been developed to protect low-voltage consumer installation against surges and effects of indirect lightning discharges and induced voltages. They are to be installed within lightning protection in zones 0_B - 2 per IEC 62305.

BENEFITS

- Category IEC / EN / VDE
- Location of use
- Protection modes
- Protective elements
- Surge discharge rating
- Internal protection and safety
- Complies with

Class II / Type 2 / C
Sub-distribution boards
L/N-PE, L-PEN, L-N, N-PE
MOV and GDT
 $I_{\max} = 40 \text{ kA}$
Separate thermal disconnecter for each MOV
IEC/EN 61643-11

ORDERING DATA

Overvoltage protection - ISPRO BS(R)	page 8-23
Connections	page 8-29
Example - Ordering data	page 8-26
Technical characteristics	page 8-28
Dimensions	page 8-29

OVERVOLTAGE PROTECTION - ISPRO C(R)

CLASS II MODULAR SINGLE-POLE SPD; $I_{max} = 40$ kA (8/20)

ISPRO C(R) 40/xxx

Type	Max. discharge current (8/20) I_{max} (kA)	Ordering No.	Weight (g)	Packaging (pcs)
ISPRO C 40/75	40	786.600.091	112	12
ISPRO C 40/150	40	786.600.092	122	12
ISPRO C 40/275	40	786.600.093	128	12
ISPRO C 40/320	40	786.600.094	128	12
ISPRO C 40/385	40	786.600.095	129	12
ISPRO C 40/440	40	786.600.096	130	12
ISPRO CR 40/75	40	786.600.097	117	12
ISPRO CR 40/150	40	786.600.098	127	12
ISPRO CR 40/275	40	786.600.099	133	12
ISPRO CR 40/320	40	786.600.100	133	12
ISPRO CR 40/385	40	786.600.101	134	12
ISPRO CR 40/440	40	786.600.102	135	12

Module ISPRO C(R) 40/xxx

Type	Max. discharge current (8/20) I_{max} (kA)	Ordering No.	Weight (g)	Packaging (pcs)
Module ISPRO C 40/75	40	786.600.194	44	12
Module ISPRO C 40/150	40	786.600.195	48	12
Module ISPRO C 40/275	40	786.600.196	52	12
Module ISPRO C 40/320	40	786.600.197	56	12
Module ISPRO C 40/385	40	786.600.198	58	12
Module ISPRO C 40/440	40	786.600.199	60	12

CLASS II MODULAR SINGLE-POLE N-PE SPD; $I_{max} = 40$ kA (8/20)

ISPRO-G C 40/255

Type	Max. discharge current (8/20) I_{max} (kA)	Ordering No.	Weight (g)	Packaging (pcs)
ISPRO-G C 40/255	40	786.600.200	118	12

Module ISPRO-G C 40/255

Type	Max. discharge current (8/20) I_{max} (kA)	Ordering No.	Weight (g)	Packaging (pcs)
Module ISPRO-G C 40/255	40	786.600.201	36	12

OVERVOLTAGE PROTECTION - ISPRO C(R)

CLASS II MODULAR MULTI-POLE SPD; $I_{max} = 40 \text{ kA (8/20)}$

ISPRO C(R) 80/xxx (2+0)

Type	Max. discharge current (8/20) I_{max} (kA)	Ordering No.	Weight (g)	Packaging (pcs)
ISPRO C 80/150 (2+0)	40 per pole	786.600.103	234	7
ISPRO C 80/275 (2+0)	40 per pole	786.600.104	244	7
ISPRO C 80/320 (2+0)	40 per pole	786.600.105	244	7
ISPRO C 80/385 (2+0)	40 per pole	786.600.106	245	7
ISPRO C 80/440 (2+0)	40 per pole	786.600.107	247	7
ISPRO CR 80/150 (2+0)	40 per pole	786.600.108	239	7
ISPRO CR 80/275 (2+0)	40 per pole	786.600.109	249	7
ISPRO CR 80/320 (2+0)	40 per pole	786.600.110	249	7
ISPRO CR 80/385 (2+0)	40 per pole	786.600.111	250	7
ISPRO CR 80/440 (2+0)	40 per pole	786.600.112	252	7

ISPRO C(R) 120/xxx (3+0)

Type	Max. discharge current (8/20) I_{max} (kA)	Ordering No.	Weight (g)	Packaging (pcs)
ISPRO C 120/150 (3+0)	40 per pole	786.600.123	330	5
ISPRO C 120/275 (3+0)	40 per pole	786.600.124	352	5
ISPRO C 120/320 (3+0)	40 per pole	786.600.125	352	5
ISPRO C 120/385 (3+0)	40 per pole	786.600.126	354	5
ISPRO C 120/440 (3+0)	40 per pole	786.600.127	356	5
ISPRO CR 120/150 (3+0)	40 per pole	786.600.128	335	5
ISPRO CR 120/275 (3+0)	40 per pole	786.600.129	357	5
ISPRO CR 120/320 (3+0)	40 per pole	786.600.130	357	5
ISPRO CR 120/385 (3+0)	40 per pole	786.600.131	359	5
ISPRO CR 120/440 (3+0)	40 per pole	786.600.132	361	5

ISPRO C(R) 160/xxx (4+0)

Type	Max. discharge current (8/20) I_{max} (kA)	Ordering No.	Weight (g)	Packaging (pcs)
ISPRO C 160/150 (4+0)	40 per pole	786.600.133	432	3
ISPRO C 160/275 (4+0)	40 per pole	786.600.134	456	3
ISPRO C 160/320 (4+0)	40 per pole	786.600.135	456	3
ISPRO C 160/385 (4+0)	40 per pole	786.600.136	460	3
ISPRO C 160/440 (4+0)	40 per pole	786.600.137	466	3
ISPRO CR 160/150 (4+0)	40 per pole	786.600.138	437	3
ISPRO CR 160/275 (4+0)	40 per pole	786.600.139	461	3
ISPRO CR 160/320 (4+0)	40 per pole	786.600.140	461	3
ISPRO CR 160/385 (4+0)	40 per pole	786.600.141	465	3
ISPRO CR 160/440 (4+0)	40 per pole	786.600.142	471	3

OVERVOLTAGE PROTECTION - ISPRO C(R)

CLASS II MODULAR MULTI-POLE SPD; $I_{max} = 40 \text{ kA}/40 \text{ kA} (8/20) \text{ L-N/N-PE}$

ISPRO C(R) 80/xxx (1+1)

Type	Max. discharge current (8/20) I_{max} (kA)	Ordering No.	Weight (g)	Packaging (pcs)
ISPRO C 80/150 (1+1)	40/40	786.600.113	221	7
ISPRO C 80/275 (1+1)	40/40	786.600.114	225	7
ISPRO C 80/320 (1+1)	40/40	786.600.115	225	7
ISPRO C 80/385 (1+1)	40/40	786.600.116	226	7
ISPRO C 80/440 (1+1)	40/40	786.600.117	227	7
ISPRO CR 80/150 (1+1)	40/40	786.600.118	226	7
ISPRO CR 80/275 (1+1)	40/40	786.600.119	230	7
ISPRO CR 80/320 (1+1)	40/40	786.600.120	230	7
ISPRO CR 80/385 (1+1)	40/40	786.600.121	231	7
ISPRO CR 80/440 (1+1)	40/40	786.600.122	232	7

ISPRO C(R) 160/xxx (3+1)

Type	Max. discharge current (8/20) I_{max} (kA)	Ordering No.	Weight (g)	Packaging (pcs)
ISPRO C 160/150 (3+1)	40/40	786.600.143	423	3
ISPRO C 160/275 (3+1)	40/40	786.600.144	441	3
ISPRO C 160/320 (3+1)	40/40	786.600.145	441	3
ISPRO C 160/385 (3+1)	40/40	786.600.146	445	3
ISPRO C 160/440 (3+1)	40/40	786.600.147	447	3
ISPRO CR 160/150 (3+1)	40/40	786.600.148	428	3
ISPRO CR 160/275 (3+1)	40/40	786.600.149	446	3
ISPRO CR 160/320 (3+1)	40/40	786.600.150	446	3
ISPRO CR 160/385 (3+1)	40/40	786.600.151	450	3
ISPRO CR 160/440 (3+1)	40/40	786.600.152	452	3

OVERVOLTAGE PROTECTION - ISPRO C(R)

CLASS II MODULAR SINGLE-POLE SPD; $I_{max} = 40 \text{ kA (8/20)}$

BENEFITS

- Category IEC / EN / VDE
 - Location of use
 - Network systems
 - Protection modes
 - Protective elements
 - Surge discharge rating
 - MOV max. withstand capability 1x8/20
 - Housing
 - Complies with
- Class II / Type 2 / C
Sub-distribution boards
TN-S, TN-C, IT, TT
L/N-PE, L-PEN
MOV
 $I_{max} = 40 \text{ kA}$
60 kA
Modular design
IEC/EN 61643-11

Type	Symbol	Unit	ISPRO C (R) 40/xxx					
			75	150	275	320	385	440
ELECTRICAL CHARACTERISTICS								
Max. continuous operating voltage (AC/DC)	U_c	V	75/100	150/200	275/350	320/420	385/500	440/580
Nominal discharge current (8/20)	I_n	kA	20					
Max. discharge current (8/20)	I_{max}	kA	40					
Protection level	U_p	kV	<0.6	<0.9	<1.5	<1.5	<1.9	<2.2
Residual voltage at 5 kA (8/20)	U_{res}	kV	<0.4	<0.6	<1.1	<1.1	<1.4	<1.6
Follow current	I_{fi}		NO					
Response time	t_A	ns	<25					
Thermal protection			Yes					
Back-up fuse (if mains >250 A)			125 A gL					
Short-circuit withstand current (50 Hz)	I_{SCCR}	kA	25					
MECHANICAL CHARACTERISTICS								
Dimensions DIN 43880			1TE					
Temperature range		°C	-40 ... 80					
Terminal screw torque		Nm	max. 3					
Terminal cross section		mm ²	35 (solid) / 25 (stranded)					
Mounting			35 mm DIN rail acc. to EN 60715					
Degree of protection			IP 20					
Housing material			Thermoplastic; extinguishing degree UL 94 V-0					
Indication material			Red flag					
Remote contacts (RC)			Yes					
Contact ratings			AC: 250 V / 0.5 A; 125 V / 3 A					
Terminal cross section		mm ²	max. 1.5					
Remote terminal torque		Nm	0.25					

OVERVOLTAGE PROTECTION - ISPRO-G C

CLASS II MODULAR SINGLE-POLE N-PE SPD; $I_{max} = 40 \text{ kA (8/20)}$

BENEFITS

- Category IEC / EN / VDE
 - Location of use
 - Network systems
 - Protection modes
 - Protective elements
 - Surge discharge rating
 - MOV max. withstand capability 1x8/20
 - Housing
 - Complies with
- Class II / Type 2 / C
Sub-distribution boards
TT
N-PE
GDT
 $I_{max} = 40 \text{ kA}$
60 kA
Modular design
IEC/EN 61643-11

Type	Symbol	Unit	ISPRO-G C (R) 40/255
ELECTRICAL CHARACTERISTICS			
Max. continuous operating voltage (AC/DC)	U_c	V	255
Nominal discharge current (8/20)	I_n	kA	20
Max. discharge current (8/20)	I_{max}	kA	40
Protection level	U_p	kV	<1.5
Follow current	I_f	A_{RMS}	100
Response time	t_A	ns	100
MECHANICAL CHARACTERISTICS			
Dimensions DIN 43880			1TE
Temperature range		°C	-40 ... 80
Terminal screw torque		Nm	max. 3
Terminal cross section		mm ²	35 (solid) / 25 (stranded)
Mounting			35 mm DIN rail acc. to EN 60715
Degree of protection			IP 20
Housing material			Thermoplastic; extinguishing degree UL 94 V-0

OVERVOLTAGE PROTECTION - ISPRO C(R)

CLASS II MODULAR MULTI-POLE SPD; $I_{\max} = 40 \text{ kA}/40 \text{ kA} (8/20) \text{ L-N/N-PE}$

BENEFITS

- Category IEC / EN / VDE
 - Location of use
 - Network systems
 - Protection modes
 - Protective elements
 - Surge discharge rating
 - MOV max. withstand capability 1x8/20
 - Housing
 - Complies with
- Class II / Type 2 / C
Sub-distribution boards
TN-S, TN-C, IT
L/N-PE, L-PEN
MOV
 $I_{\max} = 40 \text{ kA}$
60 kA per pole
Modular design
IEC/EN 61643-11

Type	Symbol	Unit	ISPRO C(R) yyy/xxx (2+0), (3+0), (4+0)				
			150	275	320	385	440
ELECTRICAL CHARACTERISTICS							
Max. continuous operating voltage (AC/DC)	U_c	V	150/200	275/350	320/420	385/500	440/580
Nominal discharge current (8/20)	I_n	kA	20 per pole				
Max. discharge current (8/20)	I_{\max}	kA	40 per pole				
Protection level	U_p	kV	<0.9	<1.5	<1.5	<1.9	<2.2
Residual voltage at 5 kA (8/20)	U_{res}	kV	<0.6	<1.1	<1.1	<1.4	<1.6
Follow current	I_{fi}		NO				
Response time	t_A	ns	<25				
Thermal protection			Yes				
Back-up fuse (if mains >250 A)			125 A gL				
Short-circuit withstand current (50 Hz)	I_{SCCR}	kA	25				
MECHANICAL CHARACTERISTICS							
Dimensions DIN 43880			2TE (2+0); 3TE (3+0); 4TE (4+0)				
Temperature range		°C	-40 ... 80				
Terminal screw torque		Nm	max. 3				
Terminal cross section		mm ²	35 (solid) / 25 (stranded)				
Mounting			35 mm DIN rail acc. to EN 60715				
Degree of protection			IP 20				
Housing material			Thermoplastic; extinguishing degree UL 94 V-0				
Indication material			Red flag				
Remote contacts (RC)			Yes				
Contact ratings			AC: 250 V / 0.5 A; 125 V / 3 A				
Terminal cross section		mm ²	max. 1.5				
Remote terminal torque		Nm	0.25				

OVERVOLTAGE PROTECTION - ISPRO C(R)

CLASS II COMPACT MULTI-POLE SPD; $I_{\max} = 40 \text{ kA}/40 \text{ kA} (8/20) \text{ L-N/N-PE}$

BENEFITS

- Category IEC / EN / VDE
 - Location of use
 - Network systems
 - Protection modes
 - Protective elements
 - Surge discharge rating
 - MOV max. withstand capability 1x8/20
 - Housing
 - Complies with
- Class II / Type 2 / C
Sub-distribution boards
TT, TN-S
L-N, N-PE
MOV and GDT
 $I_{\max} = 40 \text{ kA}$
60 kA per pole
Modular design
IEC/EN 61643-11

Type	Symbol	Unit	ISPRO C(R) yyy/xxx (1+1), (3+1)					
			150	275	320	385	440	
ELECTRICAL CHARACTERISTICS								
Max. continuous operating voltage (AC/DC)	(L-N) (N-PE)	U_c	V	150/200	275/350	320/420 255	385/500	440/580
Nominal discharge current (8/20)	(L-N/N-PE)	I_n	kA			20/20		
Max. discharge current (8/20)	(L-N/N-PE)	I_{\max}	kA			40/40		
Protection level	(L-N) (N-PE)	U_p	kV	<0.9	<1.5	<1.5	<1.9	<2.2
Residual voltage at 5 kA (8/20)	(L-N)	U_{res}	kV	<0.6	<1.1	<1.1	<1.4	<1.6
Follow current	(N-PE)	I_f	A_{RMS}			100		
Response time	(L-N/N-PE)	t_A	ns			<25/100		
Thermal protection						Yes		
Back-up fuse (if mains >250 A)	(L-N)					125 A gL		
Short-circuit withstand current (50 Hz)	(L-N)	I_{SCCR}	kA			25		
MECHANICAL CHARACTERISTICS								
Dimensions						2TE (1+1); 4TE (3+1)		
Temperature range			°C			-40 ... 80		
Terminal screw torque			Nm			max. 3		
Terminal cross section			mm ²			35 (solid) / 25 (stranded)		
Mounting						35 mm DIN rail acc. to EN 60715		
Degree of protection						IP 20		
Housing material						Thermoplastic; extinguishing degree UL 94 V-0		
Indication material						Red flag		
Remote contacts (RC)						Yes		
Contact ratings						AC: 250 V / 0.5 A; 125 V / 3 A		
Terminal cross section			mm ²			max. 1.5		
Remote terminal torque			Nm			0.25		

OVERVOLTAGE PROTECTION - ISPRO C(R)

Network connections

TN-S Network - (Single-phase)

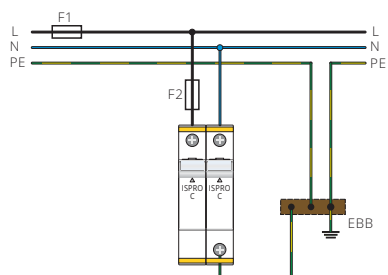

TT Network - (Single-phase)

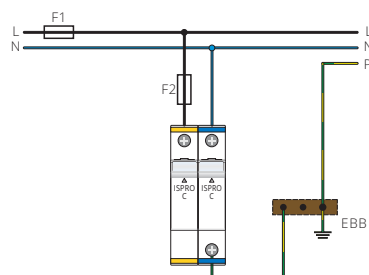

TN-C Network - (Three-phase)

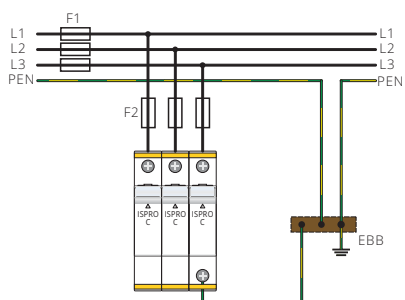

TN-S Network - (Three-phase)

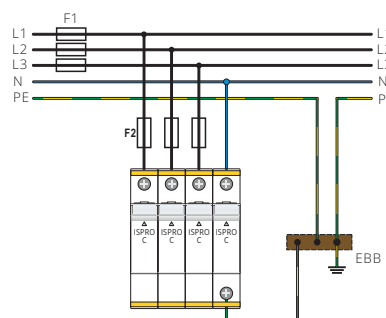

IT Network - (Three-phase)

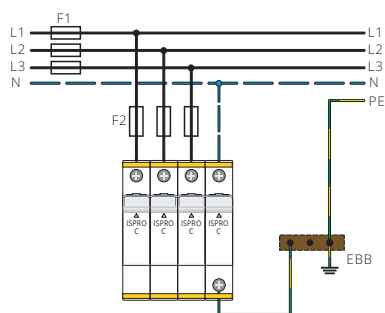

TT Network - (Three-phase)

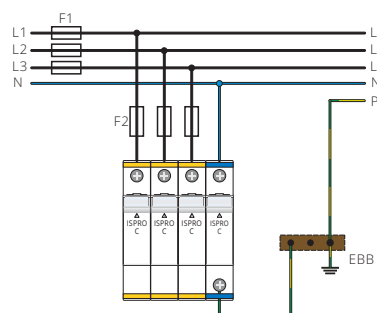

$$U_c \geq 1.1 \cdot U_n \cdot \sqrt{3}$$

Back-up fuse

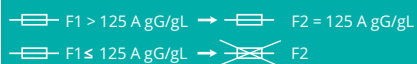

OVERVOLTAGE PROTECTION - ISPRO C(R)

ISPRO C(R) 40/xxx

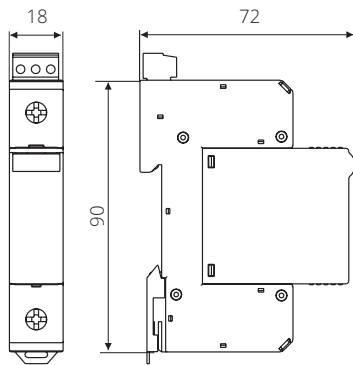

Internal configuration

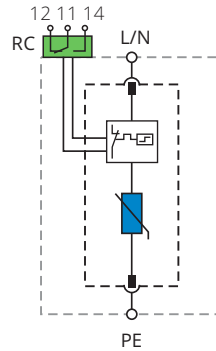

MODULE ISPRO C(R) 40/xxx

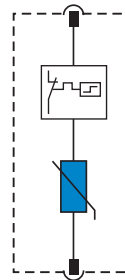
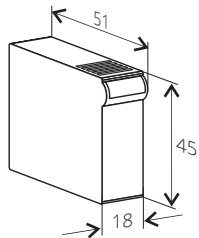

ISPRO-G C 40/255

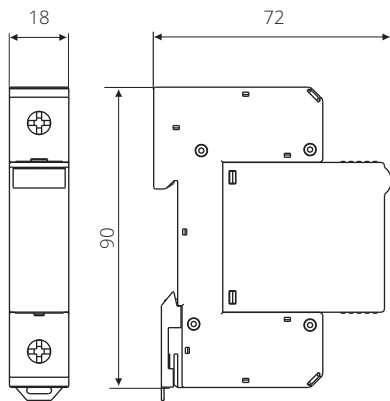

Internal configuration

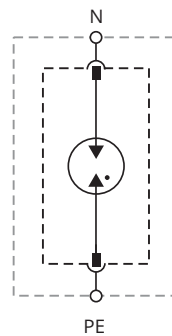

MODULE ISPRO-G C 40/255

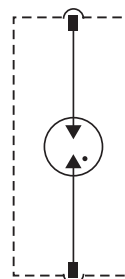
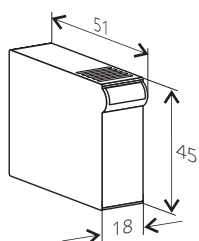

OVERVOLTAGE PROTECTION - ISPRO C(R)

ISPRO C(R) 80/xxx (2+0)

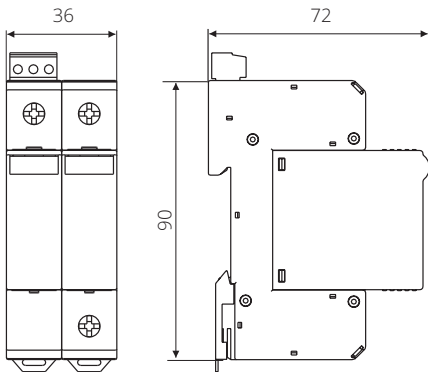

Internal configuration

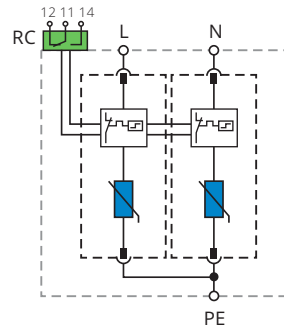

ISPRO C(R) 120/xxx (3+0)

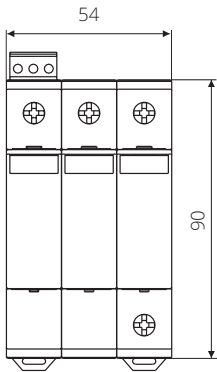

Internal configuration

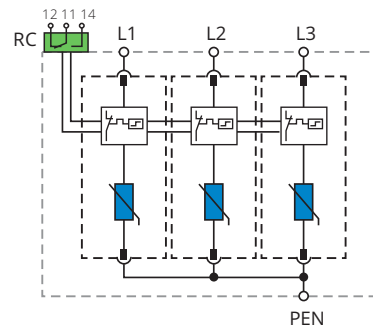

ISPRO C(R) 160/xxx (4+0)

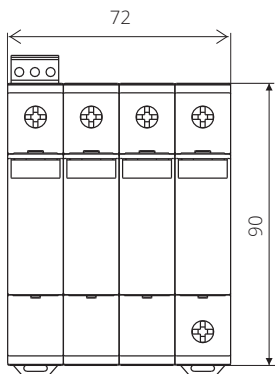

Internal configuration

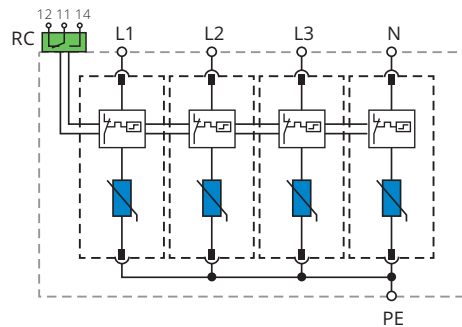

MODULE ISPRO C(R) 40/xxx

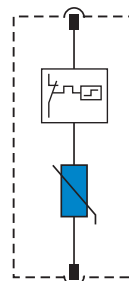
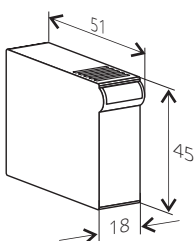

OVERVOLTAGE PROTECTION - ISPRO C(R)

ISPRO C(R) 80/xxx (1+1)

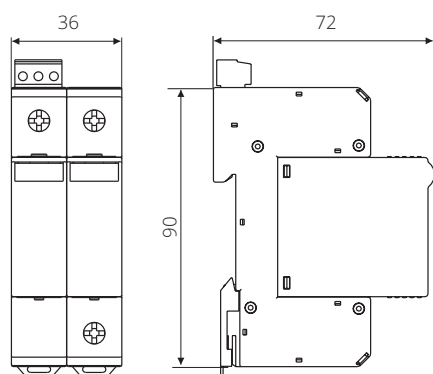

Internal configuration

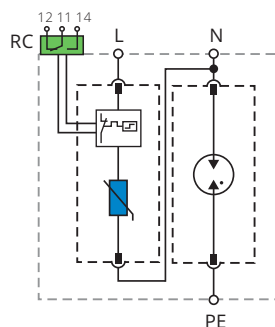

ISPRO C(R) 160/xxx (3+1)

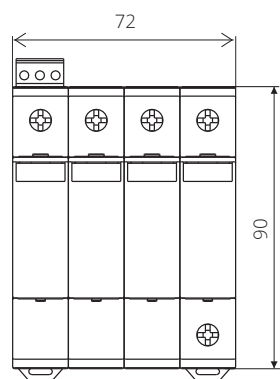

Internal configuration

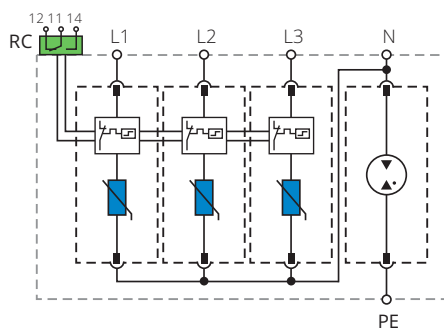

MODULE ISPRO C(R) 40/xxx

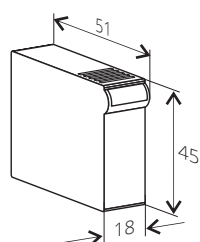

Internal configuration

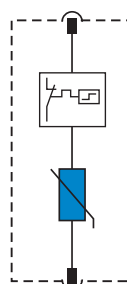

MODULE ISPRO-G C 40/255

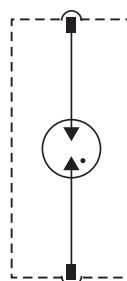
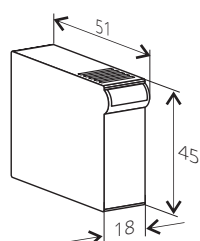

OVERVOLTAGE PROTECTION - ISPRO CM(R)

CLASS II MODULAR MULTI-POLE SPD UP TO 40 kA PER POLE



The ISPRO CM(R) series of overvoltage surge protective devices have been developed to protect low-voltage consumer installation against surges and effects of indirect lightning discharges and induced voltages. They are to be installed within lightning protection in zones O_b - 2 per IEC 62305.

BENEFITS

- Category IEC / EN / VDE
- Location of use
- Protection modes
- Protective elements
- Surge discharge rating
- Internal protection and safety
- Complies with

Class II / Type 2 / C
Sub-distribution boards
L/N-PE, L-PEN, L-N, N-PE
MOV and GDT
 I_{max} up to 40 kA
Separate thermal disconnecter for each MOV
IEC/EN 61643-11

ORDERING DATA

Overvoltage protection - ISPRO BS(R)	page 8-35
Connections	page 8-42
Example - Ordering data	page 8-38
Technical characteristics	page 8-40
Dimensions	page 8-44

OVERVOLTAGE PROTECTION - ISPRO CM(R)

CLASS II MODULAR MULTI-POLE SPD; $I_{\max} = 40 \text{ kA (8/20)}$ PER POLE

ISPRO CM(R) 80/xxx (2+0)

Type	Max. discharge current (8/20) I_{\max} (kA)	Ordering No.	Weight (g)	Packaging (pcs)
ISPRO CM 80/275 (2+0)	40 per pole	786.600.227	144	12
ISPRO CMR 80/275 (2+0)	40 per pole	786.600.228	149	12
ISPRO CMR 80/320 (2+0)	40 per pole	786.600.225	149	12

Module ISPRO CM 80/xxx (2+0)

Type	Max. discharge current (8/20) I_{\max} (kA)	Ordering No.	Weight (g)	Packaging (pcs)
Module ISPRO CM(R) 80/275	40 per pole	786.600.201	78	12
Module ISPRO CM(R) 80/320	40 per pole	786.600.201	78	12

OVERVOLTAGE PROTECTION - ISPRO CM(R)

CLASS II MODULAR MULTI-POLE SPD; $I_{\max} = 40 \text{ kA (8/20) PER POLE}$

BENEFITS

- Category IEC / EN / VDE
 - Location of use
 - Network systems
 - Protection modes
 - Protective elements
 - Surge discharge rating
 - Housing
 - Complies with
- Class II / Type 2 / C
Sub-distribution boards
TN-S
L/N-PE
MOV
 $I_{\max} = 40 \text{ kA}$
Modular design
IEC/EN 61643-11

Type	Symbol	Unit	ISPRO CM (R) 80/xxx (2+0)	
			275	320
ELECTRICAL CHARACTERISTICS				
Max. continuous operating voltage (AC/DC)	U_c	V	275/350	320/420
Nominal discharge current (8/20)	I_n	kA	15 per pole	
Max. discharge current (8/20)	I_{\max}	kA	40 per pole	
Protection level	U_p	kV	<1.4	
Follow current	I_f		NO	
Response time	t_A	ns	<25	
Thermal protection			YES	
Back-up fuse (if mains > 100 A)			100 A gL	
Short-circuit withstand current (50 Hz)	I_{SCCR}	kA	25	
MECHANICAL CHARACTERISTICS				
Dimensions DIN 43880			1TE	
Temperature range		°C	-40 ... 80	
Terminal screw torque	Upper terminals	Nm	max. 2	
	Lower terminals		max. 3	
Terminal cross section	Upper terminals	mm ²	6 (solid) / 4 (stranded)	
	Lower terminals		35 (solid) / 25 (stranded)	
Mounting			35 mm DIN rail acc. to EN 60715	
Degree of protection			IP 20	
Housing material			Thermoplastic; extinguishing degree UL 94 V-0	
Indication material			Red flag	
Remote contacts (RC)			Yes	
Contact ratings			AC: 250 V / 0.5 A; 125 V / 3 A	
Terminal cross section		mm ²	max. 1.5	
Remote terminal torque		Nm	0.25	

OVERVOLTAGE PROTECTION - ISPRO CM(R)

Network connections

TN-S Network (Single-phase)

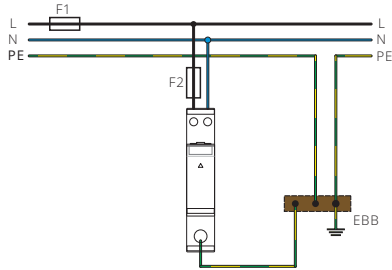

TN-S Network (Three-phase)

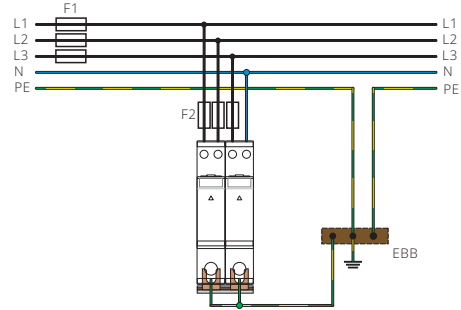

ISPRO CM(R) 80/xxx (2+0)

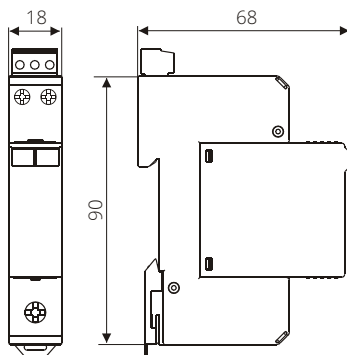

Internal configuration

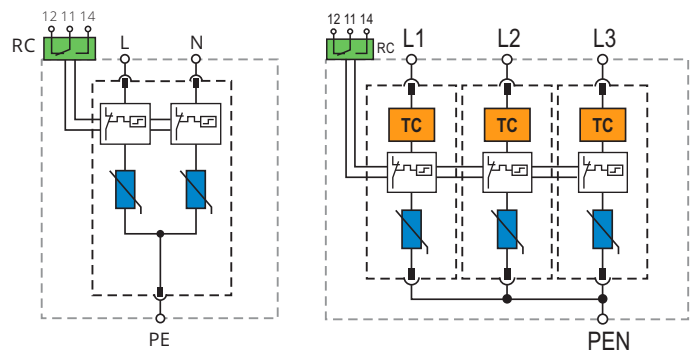

MODULE ISPRO CM(R) 80/xxx (2+0)

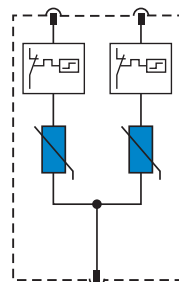
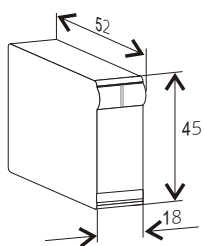

OVERVOLTAGE PROTECTION - PV ISPRO C(R)

CLASS II MODULAR MULTI-POLE SPD FOR PHOTOVOLTAIC SYSTEMS 40 kA PER POLE



The PV ISPRO C(R) series of overvoltage surge protective devices have been developed to protect against indirect lightning discharges and is intended to protect photovoltaic systems.

BENEFITS

- Category IEC / EN / VDE
- Location of use
- Protection modes
- Protective elements
- Surge discharge rating
- Safety
- Internal protection and safety
- Complies with

Class II / Type 2 / C

Photovoltaic systems - PV module side

(+)→PE, (-)→PE, (+)→(-)

MOV

$I_{max} = 40 \text{ kA}$

Ground fault immunity, ground fault withstand

Separate thermal disconnecter for each MOV

EN 50539-11

ORDERING DATA

Overvoltage protection - PV ISPRO C(R) page 8-38

Connections page 8-41

Example - Ordering data page 8-39

Technical characteristics page 8-40

Dimensions page 8-41

OVERVOLTAGE PROTECTION - PV ISPRO C(R)

CLASS II MODULAR MULTI-POLE SPD FOR PHOTOVOLTAIC SYSTEMS 40 kA PER POLE

PV ISPRO C(R) 40/xxxx

Type	Max. discharge current (8/20) I_{max} (kA)	Ordering No.	Weight (g)	Packaging (pcs)
PV ISPRO C 40/550	40	786.600.157	302	7
PV ISPRO C 40/1000	40	786.600.158	398	5
PV ISPRO CR 40/550	40	786.600.159	307	7
PV ISPRO CR 40/1000	40	786.600.160	403	5

Module PV ISPRO C 40/xxxx

Type	Max. discharge current (8/20) I_{max} (kA)	Ordering No.	Weight (g)	Packaging (pcs)
Module PV ISPRO C(R) 40/550	40	786.600.201	58	12
Module PV ISPRO C(R) 40/1000	40	786.600.201	58	12

Type	Symbol	Unit	PV ISPRO C (R) 40/xxxx	
			550	1000
ELECTRICAL CHARACTERISTICS				
Max. continuous operating voltage (DC) (+)→PE/(-)→PE per module	U_c	V	550 550	1000 500
Nominal discharge current (8/20)	I_n	kA	20 per pole	
Max. discharge current (8/20)	I_{max}	kA	40 per pole	
Protection level	U_p	kV	<1.9	<3.6
Residual voltage at 5 kA (8/20)	U_{res}	kV	<1.6	<3.0
Follow current	I_{fi}		NO	
Response time	t_A	ns	<25	
Thermal protection			YES	
MECHANICAL CHARACTERISTICS				
Dimensions DIN 43880			2TE	3TE
Temperature range		°C	-40 ... 80	
Terminal screw torque		Nm	max. 3	
Terminal cross section		mm ²	35 (solid) / 25 (stranded)	
Mounting			35 mm DIN rail acc. to EN 60715	
Degree of protection			IP 20	
Housing material			Thermoplastic; extinguishing degree UL 94 V-0	
Indication material			Red flag	
Remote contacts (RC)			Yes	
Contact ratings			AC: 250 V / 0.5 A; 125 V / 3 A	
Terminal cross section		mm ²	max. 1.5	
Remote terminal torque		Nm	0.25	

OVERVOLTAGE PROTECTION - PV ISPRO C(R)

Network connections

PV ISPRO C(R) 40/550

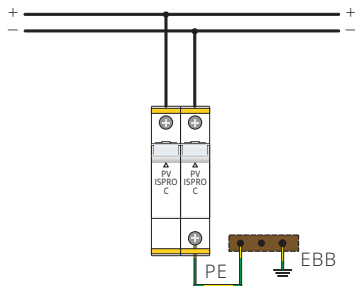

PV ISPRO C(R) 40/1000

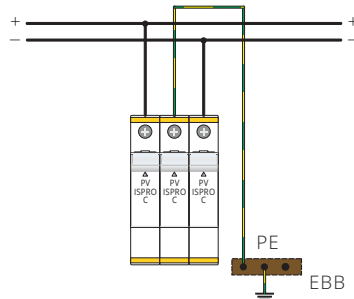

PV ISPRO C(R) 40/550

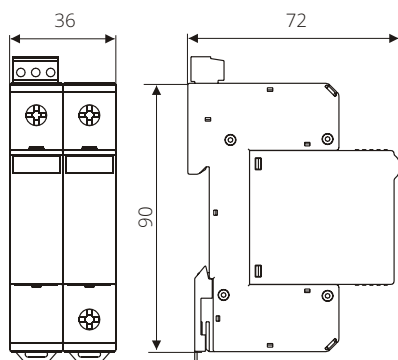

Internal configuration

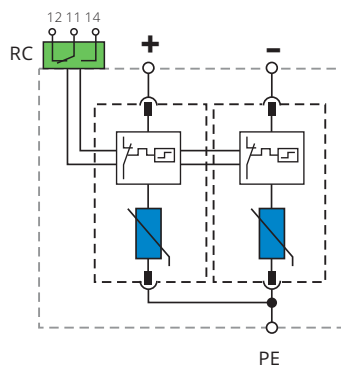

PV ISPRO C(R) 40/1000

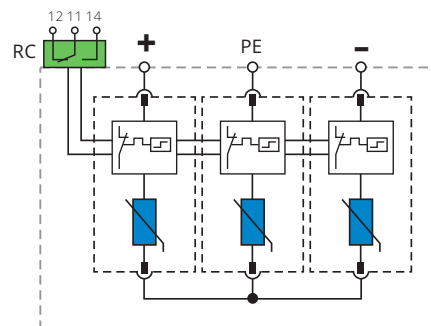
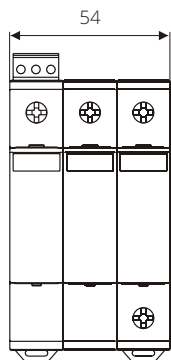

MODULE ISPRO CM(R) 80/xxx (2+0)

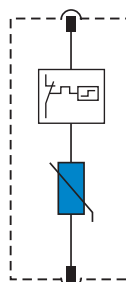
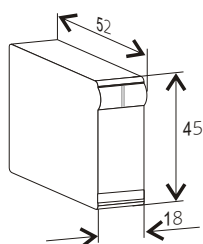

OVERVOLTAGE PROTECTION - WT ISAFE C

CLASS II MODULAR MULTI-POLE SPD FOR WIND SYSTEMS 25 kA PER POLE



The WT ISAFE series has been developed to meet the growing needs of wind generation facilities where exposure to direct and indirect lightning discharges is well known problem, primarily due to the often exposed location of such facilities e.g. on hill tops and open land topography.

BENEFITS

- Category IEC / EN / VDE
- Location of use
- Network system
- Protection modes
- Protective elements
- Surge discharge rating
- Safety
- Internal protection and safety
- Housing
- Complies with

Class II / Type 2 / C
Sub-distribution boards
TN-C
L-PEN
MOV and GDT
 I_{max} up to 40 kA
TOV withstand for unlimited time
Separate thermal disconnecter for each MOV
Modular design
IEC/EN 61643-11

ORDERING DATA

Overvoltage protection - WT ISAFE C	page 8-42
Connections	page 8-45
Example - Ordering data	page 8-43
Technical characteristics	page 8-44
Dimensions	page 8-45

OVERVOLTAGE PROTECTION - WT ISAFE C

CLASS II MODULAR MULTI-POLE SPD FOR WIND SYSTEMS 25 kA PER POLE

WT ISAFE C 750 (3+0)

Type	Max. discharge current (8/20) I_{max} (kA)	Ordering No.	Weight (g)	Packaging (pcs)
WT ISAFE C 750 (3+0)	25 per pole	786.605.063	364	5

Module PV ISPRO C 40/xxxx

Type	Max. discharge current (8/20) I_{max} (kA)	Ordering No.	Weight (g)	Packaging (pcs)
Module WT ISAFE C 750 (3+0)	25 per pole	786.600.201	78	12

Type	Symbol	Unit	WT ISAFE C 750 (3+0)
ELECTRICAL CHARACTERISTICS			
Max. continuous operating voltage (AC/DC)	U_c	V	750/1000
Nominal discharge current (8/20)	L-PEN I_n	kA	12.5 per pole
Max. discharge current (8/20)	L-PEN I_{max}	kA	25 per pole
Protection level	U_p	kV	<2.8
Residual voltage at 5 kA (8/20)	U_{res}	kV	<2.2
Follow current	I_{fi}		NO
Response time	t_A	ns	<25
Thermal protection			YES
Short-circuit withstand current (50 Hz)	I_{SCCR}	kA	25
Back-up fuse (if mains > 125 A)			125 A gL
TOV withstand for unlimited time up to	U_T	V	1000
MECHANICAL CHARACTERISTICS			
Dimensions DIN 43880			3TE
Temperature range		°C	-40 80
Terminal screw torque		Nm	max. 3
Terminal cross section		mm ²	35 (solid) / 25 (stranded)
Mounting			35 mm DIN rail acc. to EN 60715
Degree of protection			IP 20
Housing material			Thermoplastic; extinguishing degree UL 94 V-0
Indication material			Red flag
Remote contacts (RC)			Yes
Contact ratings			AC: 250 V / 0.5 A; 125 V / 3 A
Terminal cross section		mm ²	max. 1.5
Remote terminal torque		Nm	0.25

OVERVOLTAGE PROTECTION - WT ISAFE C

Network connections

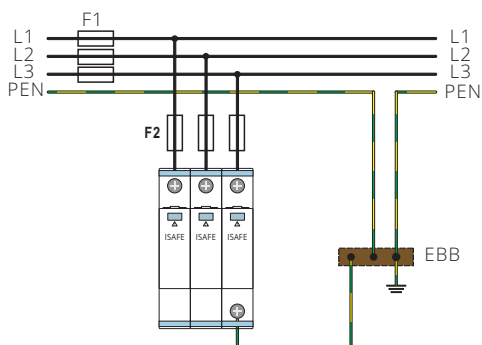

PV ISPRO C(R) 40/550

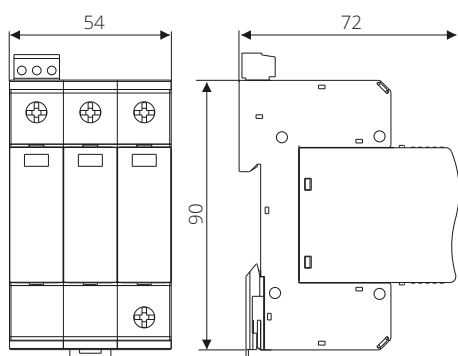

Internal configuration

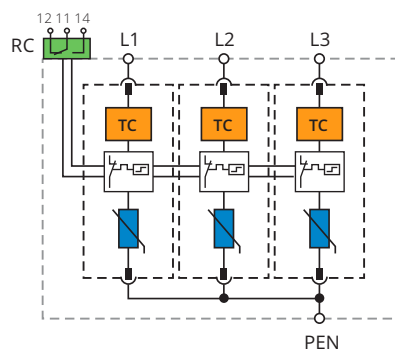

MODULE WT ISAFE C 750 (3+0)

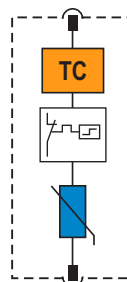
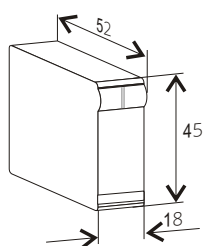

OVERVOLTAGE PROTECTION - ISPRO AQ 25

CLASS II SPD FOR OVERHEAD POWER LINES



The ISPRO AQ series of overvoltage surge protective devices has been developed to protect against indirect lightning discharges on overhead power lines. It consists of a high performance varistor with disconnection device which protects against short circuit conditions.

BENEFITS

- Category IEC / EN / VDE
- Location of use
- Protection modes
- Protective element
- Surge discharge rating
- Internal protection and safety
- Complies with

Class II / Type 2 / A
Overhead power lines
L/N-PE
MOV
 I_{max} up to 40 kA
Thermal disconnecter
IEC/EN 61643-11

ORDERING DATA

Overvoltage protection - ISPRO AQ	page 8-44
Example - Ordering data	page 8-45
Technical characteristics	page 8-45
Dimensions	page 8-46

OVERVOLTAGE PROTECTION - ISPRO AQ

CLASS II SPD FOR OVERHEAD POWER LINES

WT ISAFE C 750 (3+0)

Type	Max. discharge current (8/20) I_{max} (kA)	Ordering No.	Weight (g)	Packaging (pcs)
ISPRO AQ 25/440	25	786.600.210	112	60
ISPRO AQ 40/150	40	786.600.171	144	60
ISPRO AQ 40/275	40	786.600.172	146	60
ISPRO AQ 40/320	40	786.600.173	149	60
ISPRO AQ 40/385	40	786.600.174	154	60
ISPRO AQ 40/440	40	786.600.175	157	60

ORDERING DATA

8

Type	Symbol	Unit	PV ISPRO C (R) 40/xxxx	
			550	1000
ELECTRICAL CHARACTERISTICS				
Max. continuous operating voltage (DC) (+)→PE/(-)→PE per module	U_c	V	550 550	1000 500
Nominal discharge current (8/20)	I_n	kA	20 per pole	
Max. discharge current (8/20)	I_{max}	kA	40 per pole	
Protection level	U_p	kV	<1.9	<3.6
Residual voltage at 5 kA (8/20)	U_{res}	kV	<1.6	<3.0
Follow current	I_{fi}		NO	
Response time	t_A	ns	<25	
Thermal protection			YES	
MECHANICAL CHARACTERISTICS				
Dimensions DIN 43880			2TE	3TE
Temperature range		°C	-40 ... 80	
Terminal screw torque		Nm	max. 3	
Terminal cross section		mm ²	35 (solid) / 25 (stranded)	
Mounting			35 mm DIN rail acc. to EN 60715	
Degree of protection			IP 20	
Housing material			Thermoplastic; extinguishing degree UL 94 V-0	
Indication material			Red flag	
Remote contacts (RC)			Yes	
Contact ratings			AC: 250 V / 0.5 A; 125 V / 3 A	
Terminal cross section		mm ²	max. 1.5	
Remote terminal torque		Nm	0.25	

ORDERING DATA

OVERVOLTAGE PROTECTION - ISPRO AQ

ISPRO AQ 25
ISPRO AQ 40

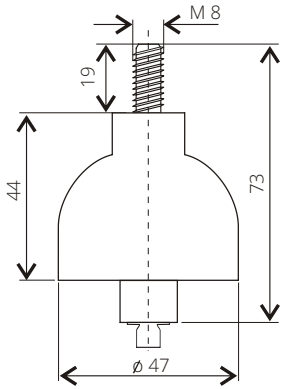

Internal configuration

