



HD2

AC Variable Speed Inverters
380/440V: 1.5kW-500kW (2HP-670HP)

HD2

High performance, torque vector inverters for AC Motors 380/440V: 1.5kW-500kW (2HP-670HP)

The HD2 range of inverters offer unrivalled performance. Designed for controlling asynchronous AC induction motors and permanent magnet synchronous motors, the HD2 torque vector control range are packed full of features that you would usually expect to find on considerably higher specified inverters.

Utilising the most advanced vector control technology, the HD2 range delivers sensorless and closed loop vector control for both asynchronous and synchronous motors giving exceptional speed response and control. HD2 offers unparalleled reliability, environmental adaptability, high precision and stable performance - everything you have come to expect from an IMO inverter drive.

The HD2 also offers some significant advantages to the customer including a huge range of functions with simple operation, international communication protocols (ModbusRTU, Profibus and CAN) along with Bluetooth and WiFi communication for programming, and with more communication options in development.

- Three-phase (380/440V) up to 500kW (670HP)
- Torque Vector Control
- Integral ModbusRTU / RS485
- Bluetooth & WiFi Communication
- Multiple Expansion Options
- Safe Torque Off (STO) as standard



Setting High Standards

The level of functionality offered by the HD2 range sets the bar high for others to compete with. For example, the HD2 offers two sets of motor parameters which allow users to deploy one HD2 inverter to control different motors, which ultimately leads to cost savings. The LCD keypad provides up to 16 lines of text and includes detailed information of parameter function with user customisable display options, along with remote mounting options for the keypad.

High Performance At Low Speeds

The HD2 range offers torque vector control across the full range. IMO is well renowned for manufacturing market-leading variable speed drives and the HD2 (along with its sister HD1 inverter) heralds a new era in feature rich inverter drives due to the vast array of standard features included that you would normally expect only to find in considerably more expensive models.

The HD2 range delivers stable torque output even at low speeds thanks to its high speed processor, allowing the HD2 to be used in an even wider range of applications including lifts, conveyor systems and high-inertia loads that demand a higher starting torque and rapid controlled braking.

Enhanced Control Functionality

As you would expect, a drive from IMO isn't your average run-of-the-mill product. We produce solutions which tick every box, every time and the HD2 is no different. From offering motor auto-tune (both static and dynamic) which minimizes power losses, to PID control which allows motor operation whilst controlling temperature, pressure and flow rate without the use of an external device or controller, together with the inclusion of programmable logic functionality and encoder feedback capability, the HD2 is so packed with features that you wouldn't believe they fit inside its compact and user-friendly form.

- Torque Vector control
- Up to 150% starting torque
- Permanent magnet motor control
- Detachable keypad with copy
- Advanced LCD keypad
- IP20 (full range)
- High speed processor
- Motor Auto-tune (static and dynamic)
- Safe Torque Off (STO)
- 2 motor parameter sets
- DC Injection braking
- Flux braking
- Integral brake chopper (<37kW)
- PID Control as standard
- PLC option card
- PG card (multiple options)
- DCR (18.5kW-110kW)

Connected For Communications

Every model in the HD2 range offers communication capability. The connection is completed by way of twisted-pair to the dedicated RS-485 terminals found on the control terminal block using the Modbus-RTU protocol or using any of the many communication option cards for which models up to and including 5.5kW can use 2 options cards simultaneously, whilst models upward of 7.5kW can use 3.

New to this range are Bluetooth and WiFi wireless communication.

- Ethernet (proprietary)
- Modbus RTU/RS485 built in
- Profibus DP card
- CANopen card
- CAN master/slave card
- Profinet card
- Bluetooth card
- WiFi card
- PLC Option Cards
- I/O Expansion Card
- 6 Digital Inputs
- 2 Analogue Inputs
- 1 Analogue Output
- 2 Relay Outputs
- USB Port for firmware updates

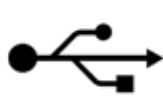

HD2 Hardware Features



HD2 Application Examples

With the array of advanced features and filter options, the HD2 is suited for use in virtually any application, whether it be industrial, commercial or domestic. The following are examples of, but not limited to, the type of application where the HD2 can be employed:-



Heavy Duty Machinery

- Oil
- Mining
- Aggregates



Hoist Applications

- RTG's
- Cranes & Lifts
- Material Handling

HD2 Terminal Layout

Terminal	Description
R01A / R02A	Relay Output N/O
R01B / R02B	Relay Output N/C
R01C / R02C	Relay Output Common
PE	Ground
PW	Input for external 24VDC supply
+24V	+24V for digital inputs
+10V	+10V for analog inputs
COM	0V common for digital inputs
CME	0V common for digital output
GND	0V common for analog input
H1	STO input 1
H2	STO input 2
S1 - S4	Digital input
HD1A / HD1B	Digital input / pulse input
AI1 / AI2	Analog input
AO1	Analog output
Y1	Digital output
HDO	Pulse output
485+	Comms +
485-	Comms -
485G	Comms ground

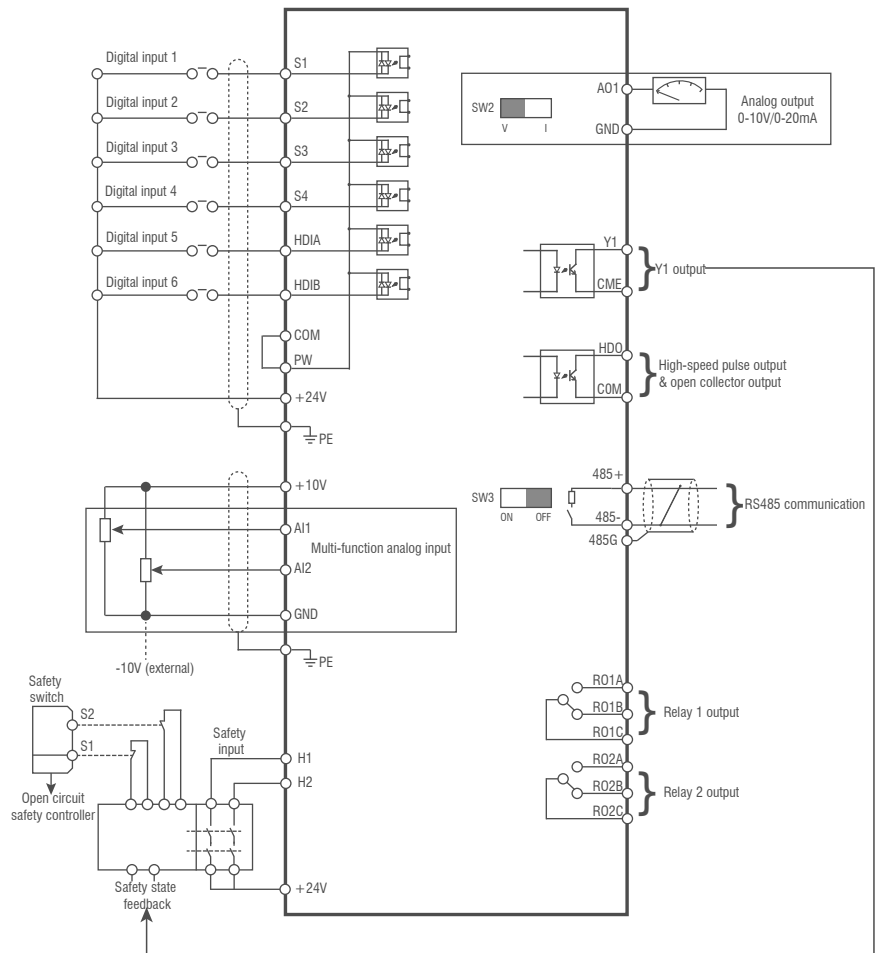

Conveyor Applications

- Metals
- Logistics
- Food Machinery



Pump & Fan Applications

- Fans
- HVAC
- Pumps
- BMS Systems
- Air Compression

Options & Ordering Information

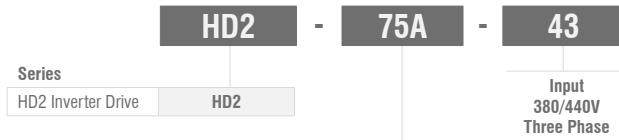

Output Power kW (HP)

1.5kW (2HP)	3.7A	90kW (125HP)	180A
2.2kW (3HP)	5A	110kW (150HP)	215A
4.0kW (5.5HP)	9.5A	132kW (175HP)	260A
5.5kW (7.5HP)	14A	160kW (215HP)	305A
7.5kW (10HP)	18.5A	185kW (250HP)	340A
11kW (15HP)	25A	200kW (270HP)	380A
15kW (20HP)	32A	220kW (300HP)	425A
18.5kW (25HP)	38A	250kW (335HP)	480A
22kW (30HP)	45A	280kW (375HP)	530A
30kW (40HP)	60A	315kW (420HP)	600A
37kW (50HP)	75A	355kW (475HP)	650A
45kW (60HP)	92A	400kW (535HP)	720A
55kW (75HP)	115A	450kW (600HP)	820A
75kW (90HP)	150A	500kW (670HP)	860A

HD2 Ratings & Specifications

	Model	Rated Power kW (HP)	Carrier Frequency (kHz)	Input Current (A)	Output Current (A)	Contactor (A)	Fuse/ MCCB (A)	Weight	Dimensions		
									Width	Height	Depth
Three Phase 440V	HD2-3.7A-43	1.5 (2)	8	5	3.7	10	17.4/16	2	126	186	184.4
	HD2-5A-43	2.2 (3)	8	5.8	5	10	17.4/16	2	126	186	185
	HD2-9.5A-43	4 (5.5)	8	13.5	9.5	16	30/25	2.5	126	186	200.9
	HD2-14A-43	5.5 (7.5)	8	19.5	14	16	45/25	2.5	126	186	200.9
	HD2-18.5A-43	7.5 (10)	8	25	18.5	25	60/40	3	146	256	191.9
	HD2-25A-43	11 (15)	8	32	25	32	78/63	6	170	320	219.2
	HD2-32A-43	15 (20)	4	40	32	50	105/63	6	170	320	219.2
	HD2-38A-43	18.5 (25)	4	47	38	63	114/100	8.5	200	340.6	207.2
	HD2-45A-43	22 (30)	4	56	45	80	138/100	8.5	200	340.6	207.2
	HD2-60A-43	30 (40)	4	70	60	95	186/125	16	250	400	222.4
	HD2-75A-43	37 (50)	4	80	75	120	228/160	16	250	400	222.4
	HD2-92A-43	45 (60)	4	94	92	135	270/200	25	282	560	257.1
	HD2-115A-43	55 (75)	4	128	115	170	315/200	25	282	560	257.1
	HD2-150A-43	75 (90)	2	160	150	230	420/250	25	282	560	257.1
	HD2-180A-43	90 (125)	2	190	180	280	480/315	41	338	554	329.2
	HD2-215A-43	110 (150)	2	225	215	315	630/400	41	338	554	329.2
	HD2-260A-43	132 (175)	2	265	260	380	720/400	85	500	870	360
	HD2-305A-43	160 (215)	2	310	305	450	870/630	85	500	870	360
	HD2-340A-43	185 (250)	2	345	340	580	1110/630	85	500	870	360
	HD2-380A-43	200 (270)	2	385	380	580	1110/630	85	500	870	360
	HD2-425A-43	220 (300)	2	430	425	630	1230/800	135	680	960	379.5
	HD2-480A-43	250 (335)	2	485	480	700	1380/800	135	680	960	379.5
	HD2-530A-43	280 (375)	2	545	530	780	1500/1000	135	680	960	379.5
	HD2-600A-43	315 (420)	2	610	600	900	1740/1200	135	680	960	379.5
HD2-650A-43	355 (475)	2	625	650	960	1860/1280	350	620	1700	560	
HD2-720A-43	400 (535)	2	715	720	1035	2010/1380	350	620	1700	560	
HD2-820A-43	450 (600)	2	840	820	1222	2445/1630	350	620	1700	560	
HD2-860A-43	500 (670)	2	890	860	1290	2505/1720	350	620	1700	560	

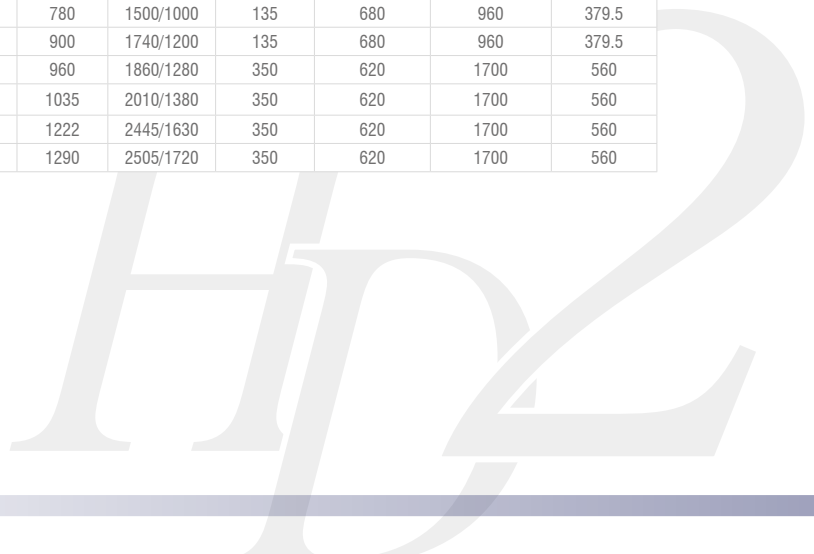

Expansion Card Selection

Expansion Card Type	Part Number	Part Description
I/O Card	HD2-E-IO	IO Expansion Card
PLC Card	HD2-E-PLC	Programmable Expansion Card (CODESYS)
Communication Card	HD2-E-BTP	Bluetooth Communication Card (Internal Antenna)
	HD2-E-BTM	Bluetooth Communication Card (External Antenna)
	HD2-E-ENET	Ethernet Communication Card
	HD2-E-WFP	WiFi Communication Card (Internal Antenna)
	HD2-E-WFM	WiFi Communication Card (External Antenna)
	HD2-E-COP	CANopen Communication Card
	HD2-E-CAN	CAN Master-Slave Communication Card
	HD2-E-PDP	PROFIBUS-DP Communication Card
PG Card	HD2-E-PGIM	Multi-Function Incremental PG Card
	HD2-E-PGI	5V Differential PG Card
	HD2-E-PGR	Rotary Transformer PG Card
Accessories	HD2-KP	LCD Multi-function keypad
	HD2-KP-MB	Keypad mounting bracket

HD2-E-IO



HD2-E-PDP



Accessories

Inverter	Input Reactor	DC Reactor	Output Reactor	Braking unit
HD2-3.7A-43	ACLC-1.5-4	N/C	OLC-1.5-4	Integral
HD2-5A-43	ACLC-2.2-4	N/C	OLC-2.2-4	Integral
HD2-9.5A-43	ACLC-4.0-4	N/C	OLC-4.0-4	Integral
HD2-14A-43	ACLC-5.5-4	N/C	OLC-5.5-4	Integral
HD2-18.5A-43	ACLC-7.5-4	N/C	OLC-7.5-4	Integral
HD2-25A-43	ACLC-11-4	N/C	OLC-11-4	Integral
HD2-32A-43	ACLC-15-4	N/C	OLC-15-4	Integral
HD2-38A-43	ACLC-18-4	Integral	OLC-18-4	Integral
HD2-45A-43	ACLC-22-4	Integral	OLC-22-4	Integral
HD2-60A-43	ACLC-37-4	Integral	OLC-37-4	Integral
HD2-75A-43	ACLC-37-4	Integral	OLC-37-4	Integral
HD2-92A-43	ACLC-45-4	Integral	OLC-45-4	DBU45/75-4
HD2-115A-43	ACLC-55-4	Integral	OLC-55-4	DBU45/75-4
HD2-150A-43	ACLC-75-4	Integral	OLC-75-4	DBU45/75-4
HD2-180A-43	ACLC-110-4	Integral	OLC-110-4	DBU90/110-4
HD2-215A-43	ACLC-110-4	Integral	OLC-110-4	DBU90/110-4
HD2-260A-43	ACLC-160-4	DCLC-132-4	OLC-200-4	DBU132-4
HD2-305A-43	ACLC-160-4	DCLC-160-4	OLC-200-4	DBU160/200-4
HD2-340A-43	ACLC-200-4	DCLC-200-4	OLC-200-4	DBU160/200-4
HD2-380A-43	ACLC-200-4	DCLC-220-4	OLC-200-4	DBU160/200-4
HD2-425A-43	ACLC-280-4	DCLC-280-4	OLC-280-4	DBU220/250-4
HD2-480A-43	ACLC-280-4	DCLC-280-4	OLC-280-4	DBU220/250-4
HD2-530A-43	ACLC-280-4	DCLC-280-4	OLC-280-4	DBU160/200-4 (x2)
HD2-600A-43	ACLC-350-4	DCLC-315-4	OLC-350-4	DBU160/200-4 (x2)
HD2-650A-43	Integral	DCLC-400-4	OLC-350-4	DBU160/200-4 (x2)
HD2-720A-43	Integral	DCLC-400-4	OLC-400-4	DBU160/200-4 (x2)
HD2-820A-43	Integral	DCLC-500-4	OLC-500-4	DBU160/200-4 (x2)
HD2-860A-43	Integral	DCLC-500-4	OLC-500-4	DBU220/250-4 (x2)

HD2-E-WFP



HD2-E-PGI



IMO Worldwide Offices

IMO Precision Controls Limited

The Interchange
Frobisher Way
Hatfield, Herts AL10 9TG
United Kingdom

Tel: 01707 414 444

Email: imo@imopc.com
Web: www.imopc.com

IMO Jeambrun Automation SAS

Parc de la Broye
14 rue du Chauffour
59710 ENNEVELIN
France

Tel: 0800 912 712 (n° gratuit)

Email: imo-fr@imopc.com
Web: www.imojeambrun.fr

IMO Automazione

Via Belfiore 10,
50144 Firenze (FI)
Italia

Tel: 800 930 872 (toll free)

Email: imo-it@imopc.com
Web: www.imopc.it

IMO Canada

1B-701 Rossland Road East
Suite #608
Whitby, Ontario L1N 9K3
Canada

Tel: 416 639 0709

Email: sales-ca@imopc.com
Web: www.imopc.com

IMO Automation LLC

Steeplechase Industrial Park
Suite E, 5845 Steeplechase Blvd
Cumming, GA 30040
USA

Tel: 404 476 8810

Email: sales-na@imopc.com
Web: www.imoautomation.com

IMO South Africa (Pty) Ltd

Unit 2, Trio Park
Prime Park, Printers Way
Cape Town 7441
South Africa

Tel: 021 551 1787

Email: info@imopc.co.za
Web: www.imopc.co.za

IMO Pacific Pty Ltd

Unit 9, Dillington Pass
Landsdale
Perth WA 6065
Australia

Tel: 1300 34 21 31

Email: sales@imopacific.com.au
Web: www.imopacific.com.au



LinkedIn
Connect with us and follow
IMO Precision Controls for the
latest news, views and reviews



Errors and omissions excepted. Subject to change without notice. Information correct at time of print.